

Modular Hi-Rise Series Fan Coils

INSTALLATION, OPERATION, & MAINTENANCE MANUAL



Modular Hi-Rise Models:

MPY, MXY, MAY/MBY Ditto,
MMY/MSY, MUY, and MGY

BUILD YOUR REPUTATION ON OURS

Modular Hi-Rise Series Fan Coils

INSTALLATION, OPERATION, & MAINTENANCE MANUAL

International Environmental Corporation (IEC) works continually to improve its products. As a result, the design and specifications of each product may be changed without notice and may not be as described herein. Please contact IEC for information regarding current design and product specifications. Statements and other information contained herein are not express warranties and do not form the basis of any bargain between the parties but are merely IEC's opinion or commendation of its products. Manufacturer's standard limited warranty applies.

Modular Hi-Rise Series Fan Coils

INSTALLATION, OPERATION, & MAINTENANCE MANUAL

SECTION I – Receipt and Initial Installation

- 4 Receipt
- 4 Unpacking and Inspection
- 5 Handling and Installation

SECTION II – Product Line Specific Installation

- 5 Part 1 – Universal Hi-Rise Units (MUY)
- 6 Potential Unit Configurations
- 6 Unit Knockout Locations (Typical)
- 7 Supply, Return, and Drain Riser Installation
- 8 Riser to Unit Installation
- 8 Riser to Drain Installation
- 10 Supply Air Installation
- 10 Part 2 – Ditto and Siamese Ditto (MAY/MBY)
- 12 Part 3 – High Rise, Ditto, and Siamese Ditto (MPY, MAY/MBY, MMY/MSY)
- 12 Supply, Return, and Drain Risers
- 13 Part 4 – Mega Mod Units (MGY)
- 14 Supply, Return, and Drain Risers
- 14 Riser to Unit Installation
- 15 Riser to Drain Installation
- 16 Unit Knockout Locations (Typical)
- 16 Supply Air Installation

SECTION III – Finishing Installation (All Models)

- 17 Grille/Ductwork Installation
- 17 Outside Air Installation (if required)
- 17 Electrical Connections
- 18 Exposed Unit Touch-up and Repainting
- 18 Concealed Unit Enclosure

SECTION IV – Start-up (All Models)

- 19 Cooling/Heating System
- 19 Air System Balancing
- 20 ECM Blower
- 21 Water Treatment
- 21 Water System Balancing
- 22 Controls Operation

SECTION V – Routine Maintenance (All Models)

- 22 Motor/Blower Assembly
- 22 Coil
- 23 Electric Resistance Heater Assembly
- 23 Electrical Wiring and Controls
- 23 Valves and Piping
- 23 Filters, Throwaway
- 24 Filters, Permanent
- 24 Drain
- 24 Replacement Parts

SECTION VI – Checklists

- 25 Receiving and Inspection
- 25 Handling and Installation
- 25 Cooling/Heating Connections
- 25 Ductwork Connections
- 25 Electrical Connections
- 25 Unit Start-up
- 26 Terms and Conditions

Modular Hi-Rise Series Fan Coils

INSTALLATION, OPERATION, & MAINTENANCE MANUAL

SECTION I – Receipt and Initial Installation

Receipt

International Environmental Corporation fan coil units represent a prudent investment offering trouble-free operation and long service with proper installation, operation, and regular maintenance.

Your equipment is initially protected under the manufacturer's standard warranty; however, this warranty is provided under the condition that the steps outlined in this manual for initial inspection, proper installation, regular periodic maintenance, and everyday operation of the equipment be followed in detail. This manual should be fully reviewed in advance before initial installation, start-up, and any maintenance. Should any questions arise, please contact your local sales representative or the factory BEFORE proceeding.

The equipment covered by this manual is available with a variety of options and accessories. Consult the approved unit submittals, order acknowledgement, and other manuals for details on unit options and accessories.

NO ATTEMPT SHOULD BE MADE TO HANDLE, INSTALL, OR SERVICE ANY UNIT WITHOUT FOLLOWING SAFE PRACTICES REGARDING MECHANICAL EQUIPMENT.

The equipment must always be properly supported. Temporary supports used during installation or service must be adequate to hold the equipment securely.

All power must be disconnected before any installation or service is attempted. More than one power source may be supplied to a unit. Power to remote mounted control devices may not be supplied through the unit.

Never wear bulky or loose fitting clothing when working on any mechanical equipment. Gloves should be worn for proper protection against heat and other possible injuries. Safety glasses or goggles should always be worn when drilling, cutting, or working with chemicals such as refrigerants or lubricants.

Never pressurize any equipment beyond specified test pressures. Always pressure test with an inert fluid or gas such as clear water or dry nitrogen to avoid possible

damage or injury in the event of a leak or component failure during testing.

Always protect adjacent flammable material when welding or soldering. Use a suitable heat- shield material to contain sparks or drops of solder. Have a fire extinguisher readily available.

The manufacturer assumes no responsibility for personal injury or property damage resulting from improper or unsafe practices during the handling, installation, service, or operation of any equipment.

Unpacking and Inspection

All units are carefully inspected at the factory throughout the manufacturing process under a strict detailed quality assurance program, and, where possible, ALL major components and sub-assemblies are carefully tested for proper operation and verified for full compliance with factory standards. Operational testing of some customer-furnished components such as electronic control valves and digital controllers may be a possible exception.

Each unit is carefully packaged for shipment to avoid damage during normal transit and handling. Equipment should always be stored in a dry place, and in the proper orientation as marked on the carton.

All shipments are made F.O.B. factory and is the responsibility of the receiving party to inspect the equipment upon arrival. Any obvious damage to the carton and/or its contents should be recorded on the bill of lading and a claim should be filed with the freight carrier.

After determining the condition of the carton exterior, carefully remove each unit from the carton and inspect for hidden damage. At this time, check to make sure that "furnished only" items such as thermostats, grilles etc. are accounted for whether packaged separately or shipped at a later date. Any hidden damage should be recorded and immediately reported to the carrier and a claim should be filed. In the event a claim for shipping damage is filed, the unit, shipping carton, and all packing must be retained for physical inspection by the freight carrier. All equipment should be stored in the factory shipping carton with internal packing in place until installation.

Modular Hi-Rise Series Fan Coils

INSTALLATION, OPERATION, & MAINTENANCE MANUAL

At the time of receipt, the equipment type and arrangement should be verified against the order documents. Should any discrepancy be found, the local sales representative should be notified immediately so that proper action may be taken. Should any questions arise concerning warranty repairs, the factory must be notified BEFORE any corrective action is taken. Where local repairs or alterations can be accomplished, the factory must be fully informed of the extent and expected cost of those repairs before work is begun. Where factory operations are required, the factory must be contacted for authorization to return equipment and a Return Authorization Number will be issued. Unauthorized return shipments of equipment and shipments not marked with an authorization number will be refused. In addition, any claims for unauthorized expenses will not be accepted by the manufacturer.

Handling and Installation

The units covered in this manual are identified by a tag on top of the unit which shows the floor and riser number for which each unit is designed. Units should not be installed at locations other than that marked on the unit identification tag. If no specific detail is shown on tag for unit location then determine configuration for the Universal unit based on information within this IOM. Should any questions arise regarding unit configuration, contact the sales representative or the factory BEFORE proceeding.

While all equipment is designed and fabricated with sturdy materials and may present a rugged appearance, great care must be taken to assure that no force or pressure be applied to the coil, risers, or piping during handling. Never use the risers to lift the unit. Also, depending on the options and accessories, some units could contain delicate components that may be damaged by improper handling. Lifting or supporting the cabinet only at the top and bottom should be avoided to maintain the straight and square cabinet alignment. The unit must be lowered into the space taking care to properly align the risers to engage the riser swaged sections on the unit below. The risers should never be bent or pushed together to be passed through the floor slot and should never be lifted up or pulled down to meet the risers on the floor below or above. The risers are designed with a

three-inch swage to accommodate a two-inch overlap and minor floor to floor variations.

The equipment covered in this manual **IS NOT** suitable for outdoor installations. The equipment should never be stored or installed where it may be subjected to a hostile environment such as rain, snow, or extreme temperatures.

During and after installation, special care must be taken to prevent foreign material such as paint, plaster, and drywall dust from being deposited in the drain pan or on the motor or blower wheels. Failure to do so may have serious adverse effects on unit operation, and in the case of the motor and blower assembly, may result in immediate or premature failure. All manufacturer's warranties are void if foreign material is allowed to be deposited on the motor or blower wheels of any unit. Some units and/or job conditions may require some form of temporary covering during construction.

While the manufacturer does not become involved in the design and selection of support methods and components, it should be noted that unacceptable system operating characteristics and/or performance may result from improper or inadequate unit structural support. Due to variations in building construction, floor plans, and unit configurations, each installation is different. The actual step-by-step method of installation may vary from unit to unit. However, the risers should be moved as little as possible to avoid damage to the unit and internal components.

On certain units, shipping screws or braces must be removed after the unit is installed. Be sure to check all tags on the unit to determine which, if any, of these devices need to be removed.

SECTION II – Product Line Specific Installation

Part 1 – Universal Hi-Rise Units (MUY)

The unique design of the Universal Modular Fan Coil unit allows for field configuration for each unit. Air discharge, riser, drain, and outside air knockouts have been strategically located on each unit. Risers, shown with unit, are for reference only. All risers are factory fabricated and shipped loose for field installation.

Modular Hi-Rise Series Fan Coils

INSTALLATION, OPERATION, & MAINTENANCE MANUAL

It is important that you identify all of the unit feature locations and which knockouts you intend to use before proceeding with the installation. Also, it must be determined whether your application requires a Mating Unit (primary/secondary) and its configuration. Consult your local sales representative or the factory for further details on primary/secondary arrangements.

Potential Unit Configurations

Risers: Three Locations—The pre-installed Supply, Return, and Drain risers (2-pipe or 4-pipe applications) can be oriented on any of three sides of the unit (see Figure 1).

NOTE: Risers can not be installed on the Return Air side of the cabinet.

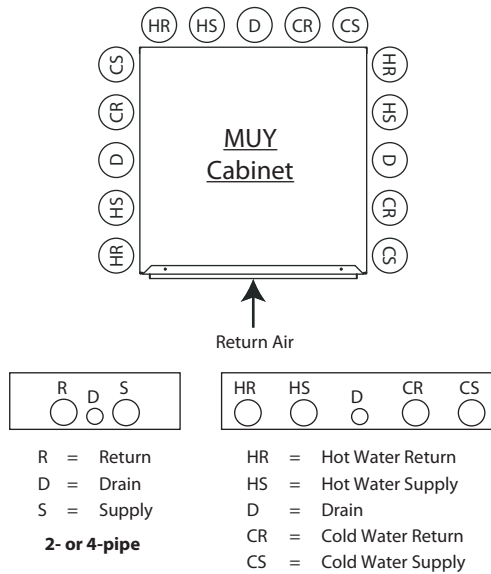

Figure 1

Unit orientation is determined based on the location of the risers in the building. The riser side of the Universal Modular unit always determines the rear of the unit (see Figure 2).

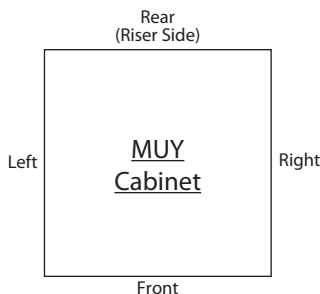

Figure 2

Return Air: Single Location—The Return Air/Access panel may then be oriented on the left, right, or front of the unit.

Supply Air: Five Locations (4 sides and top) includes stitched design for 1/2" duct flanges.

Outside Air: Two Locations—Either side adjacent to the Return Air opening.

NOTE: Outside Air opening may not be used on a side if risers are configured on that same side.

Unit Knockout Locations (Typical)

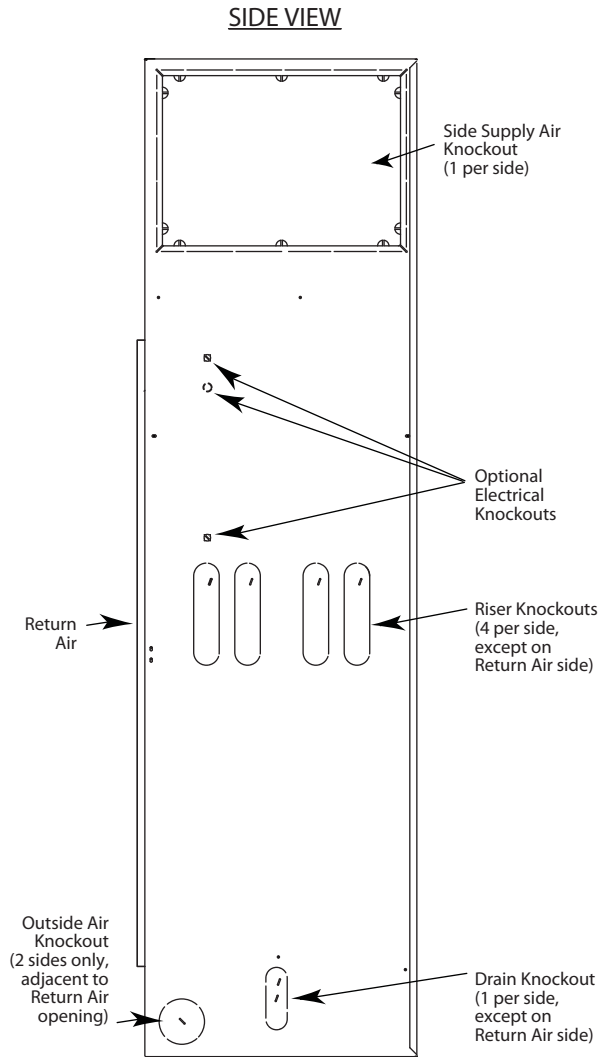

Figure 3A

Modular Hi-Rise Series Fan Coils

INSTALLATION, OPERATION, & MAINTENANCE MANUAL

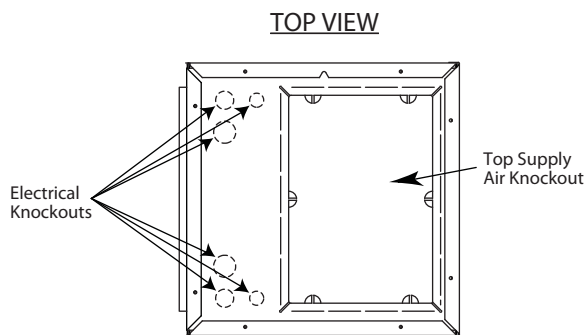

Figure 3B

KNOCKOUTS:

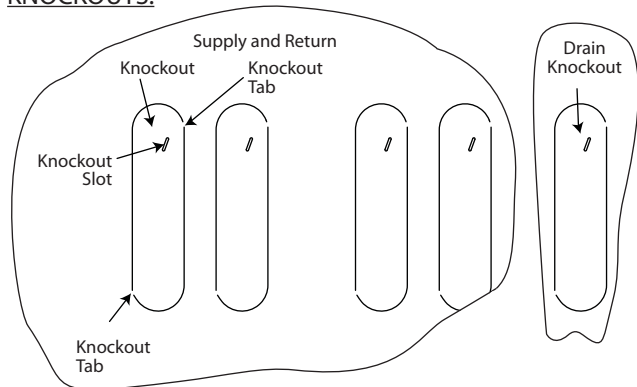

Figure 4

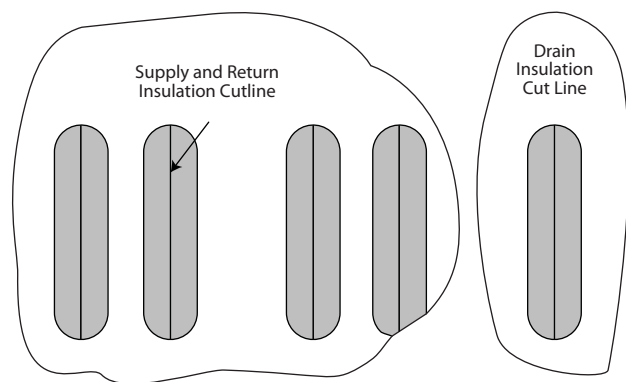

Figure 5

Supply, Return, and Drain Riser Installation

1. Three sides of each Universal Modular unit have four Supply and Return riser knockouts along the center and one Drain knockout near the lower part of the unit (see Figure 3A). Identify whether your application uses a 2-pipe or 4-pipe configuration.

- a. 2-pipe configurations: typically use the two inner riser knockouts.
 - b. 4-pipe configurations: will use all four riser knockouts.
2. Locate and mark the riser and drain knockouts that apply to your particular unit application, insuring proper orientation of the Return Air opening in room.
 3. Insert a flat head screw driver into knockout slot shown in Figure 4.
 4. Pry screw driver back and forth until knockout tabs break away from the unit.
 5. Discard knockout. Be careful of sharp edges.
 6. Use a sharp retractable knife (see Figure 5) and vertically cut the insulation down the center of the riser and drain knockouts the full length of the knockout.
 7. Use adhesive or glue to re-attach insulation that has pulled away from the unit during knockout removal process.



CAUTION: Toxic residues and loose particles resulting from manufacturing and field piping techniques such as joint compounds, soldering flux, and metal shavings may be present in the unit and the piping system. Special consideration must be given to system cleanliness when connecting to solar, domestic or potable water systems.

Submittals and product literature detailing unit operation, controls, and connections should be thoroughly reviewed **BEFORE** beginning the connection and testing of risers and piping.

To assure optimal unit performance, the supply connection(s) are marked on the unit's coil with an "S" meaning supply or inlet and "R" meaning return or outlet indicating flow direction to and from the coil. Blue letters mark the chilled water connections and red letters mark the hot water connections.

The unit's internal piping is designed to accommodate a total riser vertical movement of $\pm 1\frac{1}{2}$ " due to thermal expansion and/or contraction, when positioned properly at the job site. Risers must be anchored to the building structure to limit expansion and contraction movement to a maximum of 3". Riser anchoring and expansion

Modular Hi-Rise Series Fan Coils

INSTALLATION, OPERATION, & MAINTENANCE MANUAL

compensation is not included in the unit and must be provided. Riser end caps, air vents, and/or flushing loops must be provided at the jobsite by the installer.

Proper field riser installation and vertical positioning in the unit should have a pipe run-out to the service valves which are centered in the knockout access slots and that slope down slightly away from the riser (see Figure 6). This prevents condensation from running back to the riser and possible damage from dripping at the bottom of a riser column. Each job has specific requirements and satisfying those requirements is the responsibility of the installer.

Riser to Unit Installation

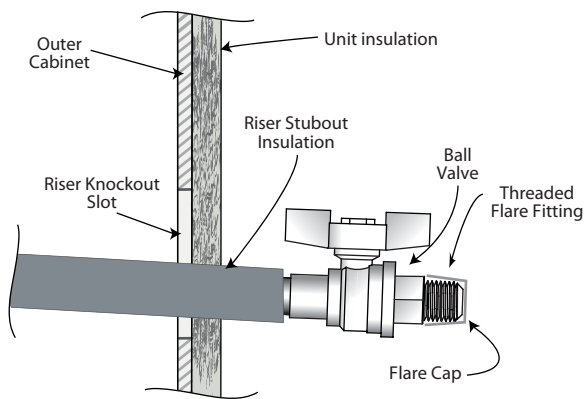

Figure 6

Before making the riser joints, the riser insulation must be pulled back away from the joint and protected from heat during the brazing process. Each riser joint must be in vertical alignment. Variations in floor-to-floor dimensions may require field work such as cutting off or extending the risers. This operation is the responsibility of the installer. The riser joint filler material must be selected to withstand the total operating pressure (both static and pumping head) to which the system will be subjected. Low temperature lead alloy solders such as "50/50" and "60/40" are normally not suitable.

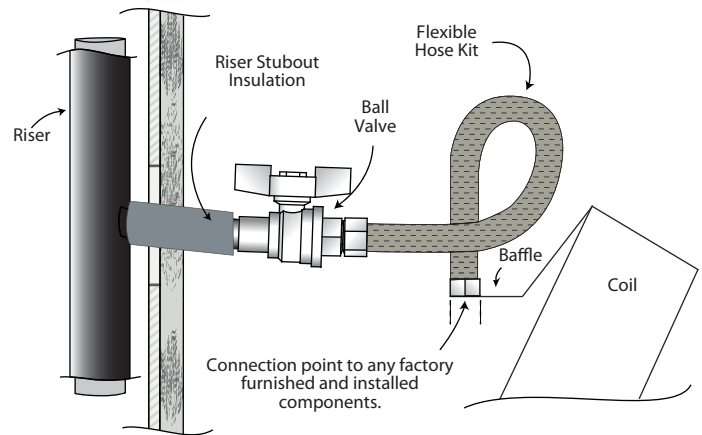

Figure 7

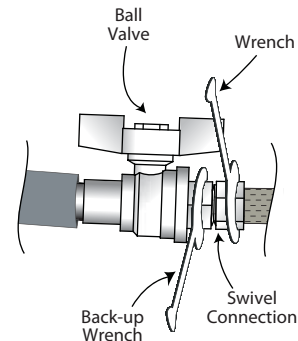

Figure 8

Riser to Drain Installation

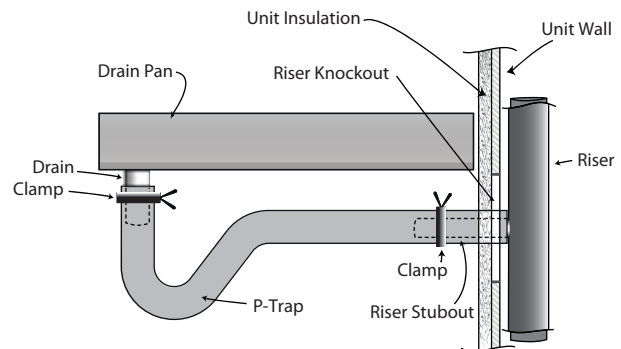

Figure 9

1. After the applicable Supply, Return, and Drain knockouts have been removed, carefully position the unit so that the riser ball valves penetrate into the unit through the riser knockouts making sure the insulation penetrates into the unit as shown in Figures 6, 7, and 9.

Modular Hi-Rise Series Fan Coils

INSTALLATION, OPERATION, & MAINTENANCE MANUAL

2. Before anchoring the equipment in place, the unit must be leveled and the cabinet must be plumb and squared.

The unit may be anchored in place by bolting directly through the unit floor or attaching to the cabinet in some location that will not interfere with drywall or other items such as the supply grille, thermostat, or return access panel. When attaching to the unit cabinet, care must be taken to not penetrate the cabinet in locations that may damage internal components or wiring. The mounting technique is a matter of choice; however, the unit should always be anchored securely to prevent movement during construction and riser expansion and contraction.

After anchoring the unit, it is then ready for the various service connections such as riser connections and electrical.

3. The plastic flare caps on the end of the riser ball valves should be removed and discarded.
4. All Universal Modular units use reinforced braided stainless steel flexible hose kits for piping between field installed risers and unit water coils as shown in Figure 7. The hose kit design has threaded connections on each end. The hose kits allow for riser fluctuations due to thermal expansion.
5. Use a wrench to tighten the swivel connections. Use a backup wrench to hold the riser ball valve stationary to prevent it from bending or twisting during installation as shown in Figure 8. Be careful to not over tighten swivel connections.



CAUTION: Hose connection torque requirements are 350 in. lbs. +10/-0 in. lbs. to prevent leaks.

6. Locate the unit's coil fitting.
7. The plastic flare caps on the end of the coil fitting should be removed and discarded.
8. Use a wrench to tighten the swivel connections. The baffle acts as a secondary wrench. Be careful to not over tighten swivel connections.



CAUTION: Hose connection torque requirements are 350 in. lbs. +10/-0 in. lbs. to prevent leaks.

9. Locate the p-trap drain and rubber hose factory installed to the drain pan connection in the bottom of the unit as shown in Figure 9.
10. Push the rubber drain hose over the riser drain stubout. Be careful that you do not bend the drain stubout.
11. Adjust the hose clamp over the riser stubout and rubber hose to hold in place as shown in Figure 9.
12. Test for leaks. Any and all leaks should be repaired before proceeding with installation. When testing with air or some other gas, it might be necessary to tighten stem packing nuts on some valves to maintain air pressure in the riser. Pressure testing risers with water should be done with the unit service valves closed to prevent flushing debris into the unit valve packages. This will also allow risers to be drained down after testing in the winter to avoid freeze-up problems. In the event that leaking or defective components are discovered, the sales representative must be notified **BEFORE** any repairs are attempted. All leaks should be repaired before proceeding with the unit installation.
13. After system integrity has been established, the riser insulation must be pulled back into place over the joint and glued or sealed to prevent sweating and heat loss or gain. All of the risers including the riser stubouts should be properly covered with insulation. Internally mounted chilled water piping and valves are located over the drain pan and need not be insulated.

Any fireproofing requirements where risers or piping penetrate floors or walls are the responsibility of the installer. This work should be done only after all pressure testing is completed. The fireproofing method used must accommodate pipe expansion and contraction and the piping must be protected from abrasion and chemical attack. The pipe insulation also must be maintained to prevent sweating and must be protected from wear or erosion at the joint between the insulation and the fireproofing material.

Modular Hi-Rise Series Fan Coils

INSTALLATION, OPERATION, & MAINTENANCE MANUAL

When no risers are ordered for the Universal Modular unit, it is the responsibility of the installer to make sure that an isolation ball valve is installed between each supply and return piping connection to the unit. Flare fittings are factory provided to allow connection between the ball valves and the hoses.

Supply Air Installation

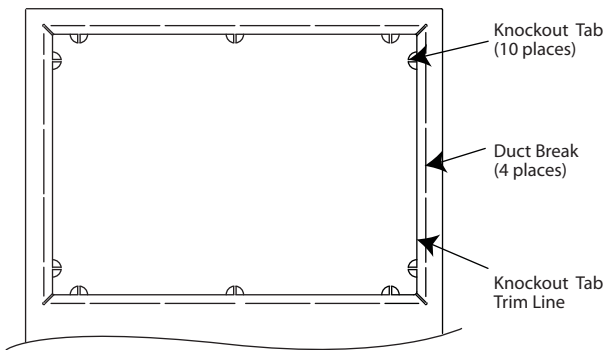

Figure 10

1. Each side of the unit has one supply air knockout as well as a supply air knockout on the top of the unit (see Figures 3A and 3B).
2. Determine which supply air opening/openings are required for your application.
NOTE: The supply air opening on the riser side of the unit should not be used.
3. Use a sharp retractable knife to trim insulation using center knockout slot/trim line as pattern (see Figure 10).
4. Use a sharp standard needle nose pliers and grab knockout tab (see Figure 10).
5. Twist or pry pliers back and forth until knockout tab breaks away from unit.
6. Repeat for all supply air tabs until all have been broken.
7. Discard center knockout piece. Be careful of sharp edges.
8. Use a sharp retractable knife to trim any excess insulation using knockout hole as pattern.

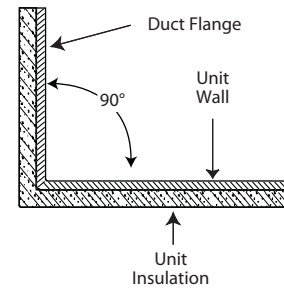

Figure 11

9. Use duct pliers (hand seamers) to fold duct flange out of the unit 90° for each side of the supply air opening along duct break (see Figure 10). The 90° flanges can now be used as drywall stops to prevent coverage of discharge opening (see Figure 11).
10. Use adhesive or glue to re-attach insulation that has pulled away from the unit during knockout removal process.
11. For ducted applications tape should be applied along and around all of the supply air opening knockouts to prevent air leakage.

All installations should be made in compliance with all governing codes and ordinances. **Compliance with all codes is the responsibility of the installing contractor.**

Part 2 – Ditto and Siamese Ditto (MAY/MBY)

The Ditto and Siamese Ditto Modular Hi-Rise Fan Coils have been designed to serve two separate rooms. These products are classified by Underwriters Laboratories Inc. for use in Penetration Firestop Systems. Control Number 27WL. They carry a one-hour rating. See UL Fire Resistance Directory for more information.

Modular Hi-Rise Series Fan Coils

INSTALLATION, OPERATION, & MAINTENANCE MANUAL

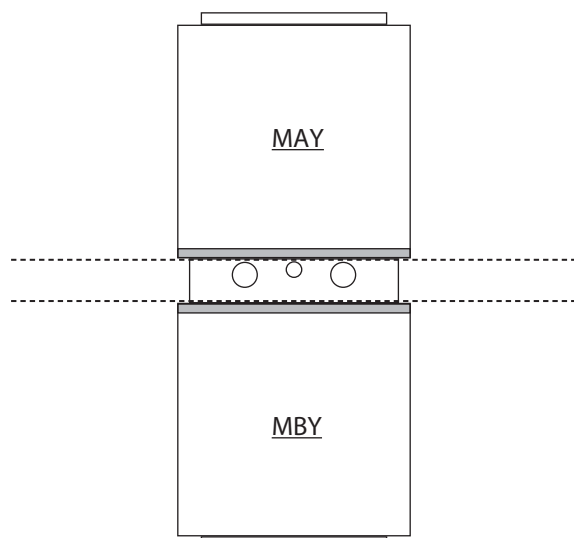

Figure 12 – Ditto

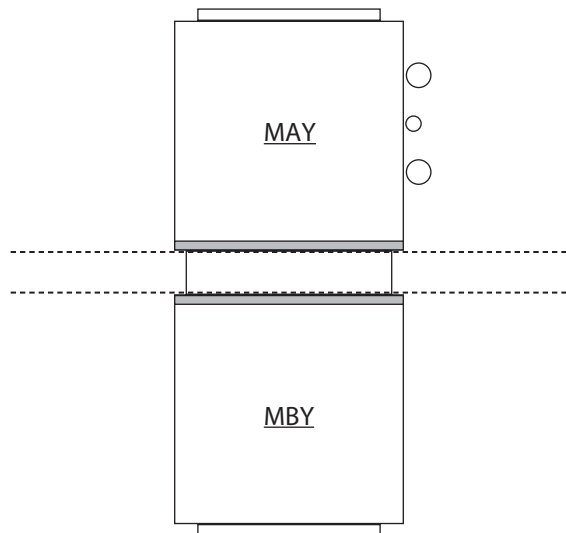

Figure 13 – Siamese Ditto

The control lines for the drywall track and studs should be laid out in the floor and ceiling (A) (see Figure 14).

Tracking may be installed now or after the unit is set.

Position the Ditto or Siamese Ditto fan coil assembly between two rooms with the unit drywall separation spotted over the wall control lines.

If not already installed, install the floor and ceiling tracks up to and over the Ditto or Siamese Ditto Fan Coil unit.

Next, position the vertical studs and fasten into each of the stud pockets formed into the chase side panels (B) (see Figure 14).

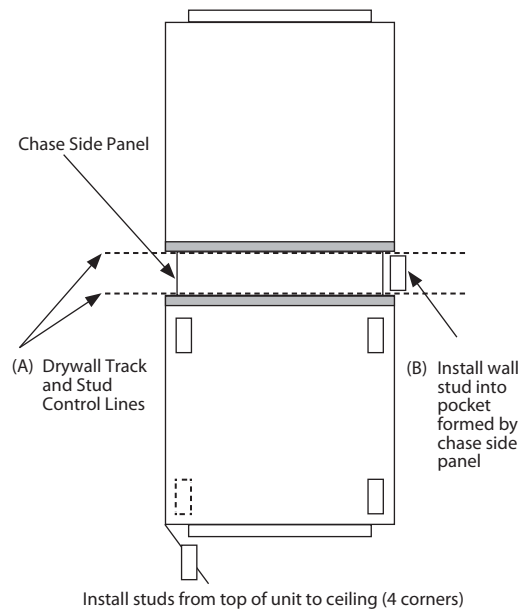

Figure 14 – Unit As Shipped

The studs may be mechanically fastened to the Ditto or Siamese Ditto Fan Coil. Care should be taken, however, not to penetrate the supply or return water risers or internal piping.

Given the levelness of the floor and/or the fan coil assembly, some shimming may be necessary.

Assemble the specified wall construction up to and over the top of the fan coil unit (C) (see Figure 15).

With the fire-wall separation being complete, the drywall skin on the surface of the individual fan coils can be applied. Drywall can be applied directly to the surface, or, if necessary, studding may be installed on the corners for vertical control (D) (see Figure 15).

For ease of installation of the access panel, apply drywall on the return air side directly to the surface of the unit (E) (see Figure 15). When applying the wall board directly to the unit cabinet, it may be necessary to shim the wall board in some areas to achieve the desired finished wall surface.

After all drywalling and painting is complete, install thermostats, supply air grilles and return air panels.

Modular Hi-Rise Series Fan Coils

INSTALLATION, OPERATION, & MAINTENANCE MANUAL



CAUTION: Avoid penetrating the riser, coil, piping and electrical system with sheetrock screws.

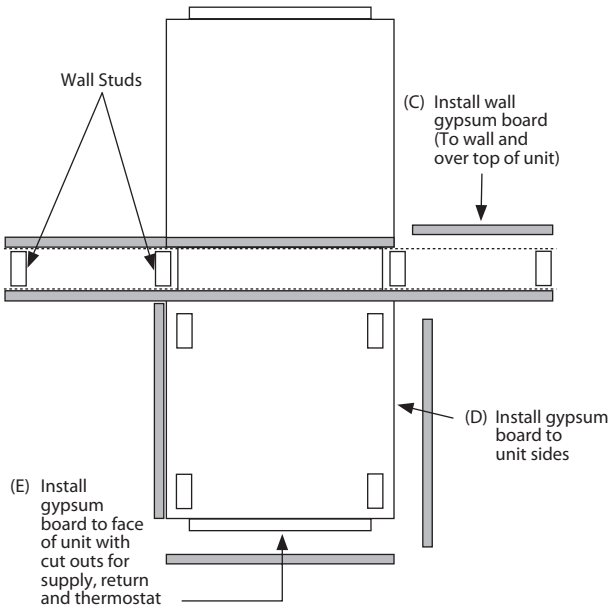

Figure 15 – On-Site Installation

Part 3 – High Rise, Ditto, and Siamese Ditto (MPY, MAY/MBY, MMY/MSY)

Supply, Return, and Drain Risers



CAUTION: Toxic residues and loose particles resulting from manufacturing and field piping techniques such as joint compounds, soldering flux, and metal shavings may be present in the unit and the piping system. Special consideration must be given to system cleanliness when connecting to solar, domestic or potable water systems.

Submittals and product literature detailing unit operation, controls, and connections should be thoroughly reviewed **BEFORE** beginning the connection and testing of risers and piping.

The supply and return connections are marked on the coil stub-outs and the valve package with an “S” meaning supply or inlet and “R” meaning return or outlet indicating flow direction to and from the coil. Blue letters mark the

chilled water connections and red letters mark the hot water connections.

The unit internal piping is designed to accommodate a total riser vertical movement of $\pm 3/4$ " due to thermal expansion and/or contraction, when positioned properly at the job site. Risers must be anchored to the building structure to limit expansion and contraction movement to a maximum of 1 1/2". Riser anchoring and expansion compensation is not included in the factory-supplied unit and must be field provided. While some special riser features are available from the factory, riser end caps, air vents, and/or flushing loops are normally provided on the job by the installer.

Proper riser installation and vertical positioning in the unit provides for a unit piping run-out to the service valves which are centered in the access slots and level or sloping down slightly away from the riser. This prevents condensation from running back to the riser and possible damage from dripping at the bottom of a riser column. Each job has specific requirements and satisfying those requirements is the responsibility of the installer.

Before making the riser joints, the riser insulation must be pulled back away from the joint and protected from heat during the brazing process. Each riser joint must be in vertical alignment. Variations in floor-to-floor dimensions may require field work such as cutting off or extending the risers. This operation is the responsibility of the installer. The riser joint filler material must be selected to withstand the total operating pressure (both static and pumping head) to which the system will be subjected. Low temperature lead alloy solders such as “50/50” and “60/40” are normally not suitable.

Chilled water and hot water risers should never be piped to drain down into the condensate riser. Extensive water damage can occur due to drain overflow. Drain chilled and hot water risers to a remote location away from the unit such as sink, room and floor drains.

After the connections are completed, the system should then be tested for leaks. When testing with air or some other gas, it might be necessary to tighten stem packing nuts on some valves to maintain air pressure in the riser. Pressure testing risers with water should be done with the unit service valves closed to prevent flushing debris into the unit

Modular Hi-Rise Series Fan Coils

INSTALLATION, OPERATION, & MAINTENANCE MANUAL

valve packages. This will also allow risers to be drained down after testing in the winter to avoid freeze-up problems.

In the event that leaking or defective components are discovered, the sales representative must be notified **BEFORE** any repairs are attempted. All leaks should be repaired before proceeding with the installation.

After system integrity has been established, the riser insulation must be pulled back into place over the joint and glued or sealed to prevent sweating and heat loss or gain. Internal chilled water piping and valves are located over the drain pan and need not be insulated.

Any fireproofing requirements where risers or piping penetrate floors or walls are the responsibility of the installer. This work should be done only after all pressure testing is completed. The fireproofing method used must accommodate pipe expansion and contraction and the piping must be protected from abrasion and chemical attack. The pipe insulation also must be maintained to prevent sweating and must be protected from wear or erosion at the joint between the insulation and the fireproofing material.

Before anchoring the equipment in place, the unit must be leveled and the cabinet must be squared and brought into line with any adjacent or included walls.

The unit may be anchored in place by bolting directly through the unit floor or attaching to the cabinet in some location that will not interfere with drywall or other items such as the supply grille, thermostat, or return access panel. When attaching to the unit cabinet, care must be taken to not penetrate the cabinet in locations that may damage internal components or wiring. The mounting technique is a matter of choice; however, the unit should always be anchored securely to prevent movement during construction and riser expansion and contraction.

After anchoring the unit, it is then ready for the various service connections such as riser joints and electrical. At this time, it should be verified that the proper types of service are actually provided to the unit. On those units requiring chilled water and/or hot water, the proper main size and water temperature should be available to the unit. The electrical service to the unit should be compared to

the unit nameplate to verify compatibility. The routing and sizing of all piping, and the type and sizing of all wiring and other electrical components such as circuit breakers, disconnect switches, etc. should be determined by the individual job requirements, and should not be based on the size and/or type of connection provided on the equipment. All installations should be made in compliance with all governing codes and ordinances. **Compliance with all codes is the responsibility of the installing contractor.**

Part 4 – Mega Mod Units (MGY)

The unique design of the Mega Modular Fan Coil unit allows for field configuration of each unit. Risers, shown with unit, are for reference only. All risers are factory fabricated and shipped loose for field installation.

It is important that you identify all of the unit feature locations before proceeding with the installation. Also, it must be determined whether your application requires a Mating Unit (primary/secondary) and its configurations. Consult your local sales representative or the factory for further details on primary/secondary arrangements.

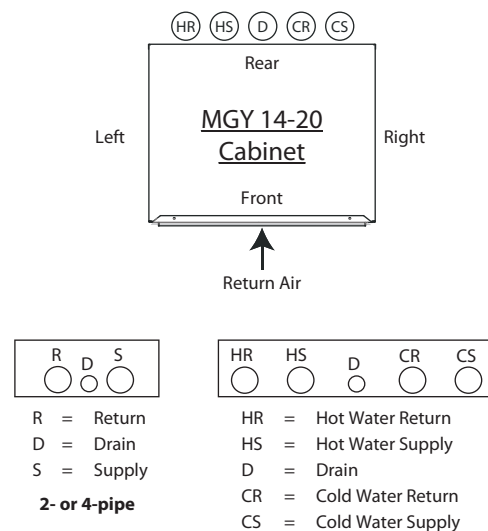

Figure 16

Unit orientation is determined based on the location of the risers in the building. Risers can only be installed on the rear side of the unit and it always determines the rear of the Mega Mod unit. The return air is always on the front (see Figure 16).

Modular Hi-Rise Series Fan Coils

INSTALLATION, OPERATION, & MAINTENANCE MANUAL

Supply, Return, and Drain Risers



CAUTION: Toxic residues and loose particles resulting from manufacturing and field piping techniques such as joint compounds, soldering flux, and metal shavings may be present in the unit and the piping system. Special consideration must be given to system cleanliness when connecting to solar, domestic or potable water systems.

Submittals and product literature detailing unit operation, controls, and connections should be thoroughly reviewed **BEFORE** beginning the connection and testing of risers and piping.

The supply and return connections are marked on the coil stub-outs and the valve package depending on your configuration. "CS" means cold water supply, "CR" means cold water return, "HS" means hot water supply, and "HR" means hot water return to indicate flow direction to and from the coil. Blue letters mark the chilled water connections and red letters mark the hot water connections.

The unit internal piping is designed to accommodate a total riser vertical movement of $\pm 1\frac{1}{2}$ " due to thermal expansion and/or contraction, when positioned properly at the job site. Risers must be anchored to the building structure to limit riser expansion and contraction movement to a maximum of 3". Riser anchoring and expansion compensation is not included in the factory-supplied unit and must be field provided. While some special riser features are available from the factory, riser end caps, air vents, and/or flushing loops are normally provided on the job by the installer.

Proper riser installation and vertical positioning in the unit provides for a unit piping run-out to the service valves which are centered in the access slots and level or sloping down slightly away from the riser. This prevents condensation from running back to the riser and possible damage from dripping at the bottom of a riser column. Each job has specific requirements and satisfying those requirements is the responsibility of the installer.

Riser to Unit Installation

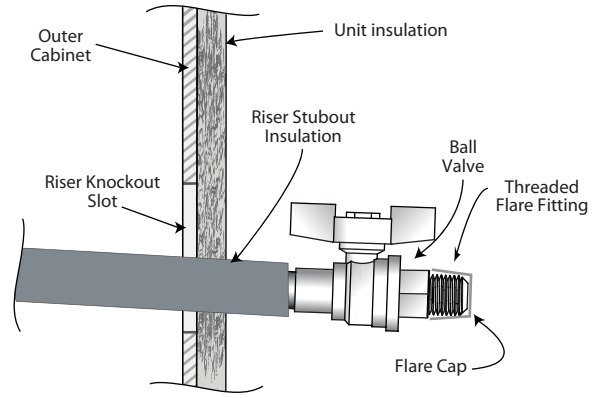

Figure 17

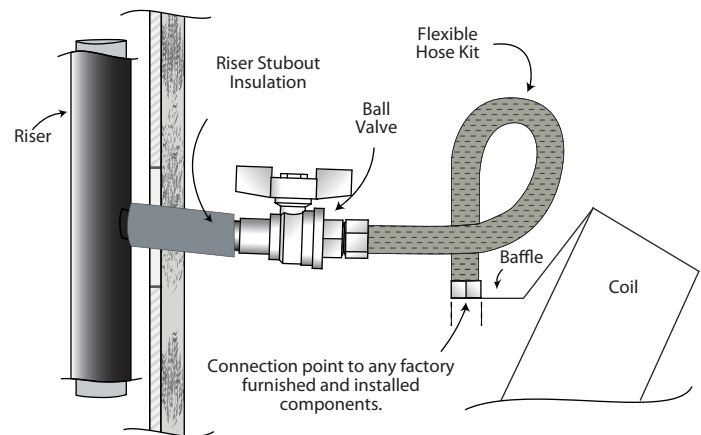

Figure 18

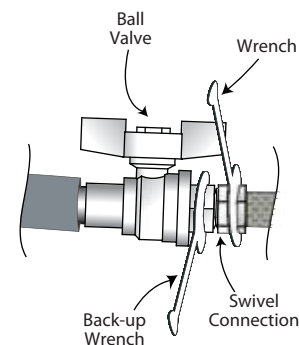

Figure 19

Riser to Drain Installation

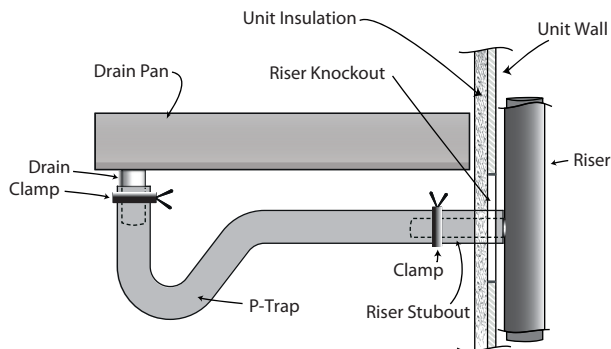

Figure 20

1. Carefully position the unit so that the riser ball valves penetrate into the unit through the riser slot making sure the insulation penetrates into the unit as shown in Figures 17 and 18.

2. Before anchoring the equipment in place, the unit must be leveled and the cabinet must be plumb and squared.

The unit may be anchored in place by bolting directly through the unit's floor or attaching to the buildings walls through the cabinet walls in some location that will not interfere with drywall or other items such as the supply grille, thermostat, or return access panel. When attaching sheetrock to the unit cabinet, care must be taken to not penetrate the cabinet in locations that may damage internal components or wiring. The mounting technique is a matter of choice; however, the unit should always be anchored securely to the building to prevent movement during construction and riser expansion and contraction.

After anchoring the unit, it is then ready for the various service connections such as riser connections and electrical.

3. The plastic flare caps on the end of the riser ball valves should be removed and discarded.
4. All Mega Modular units use reinforced braided stainless steel flexible hose kits for piping between field installed risers and unit water coils as shown in Figure 18. Each hose has threaded connections on each end. The hose kits allow for riser fluctuations due to thermal expansion.

5. Use a wrench to tighten the swivel connections. Use a backup wrench to hold the riser ball valve stationary to prevent it from bending or twisting during installation as shown in Figure 19. Be careful to not over tighten swivel connections.



CAUTION: Hose connection torque requirements are 350 in. lbs. +10/-0 in. lbs. to prevent leaks.

6. Locate the unit's coil fitting.
7. The plastic flare caps on the end of the coil fitting should be removed and discarded.
8. Use a wrench to tighten the swivel connections. The baffle acts as a secondary wrench. Be careful to not over tighten swivel connections.



CAUTION: Hose connection torque requirements are 350 in. lbs. +10/-0 in. lbs. to prevent leaks.

9. Locate the p-trap drain and rubber hose factory installed to the drain pan connection in the bottom of the unit as shown in Figure 20.
10. Push the rubber drain hose over the riser drain stubout. Be careful that you do not bend the drain stubout.
11. Adjust the hose clamp over the riser stubout and rubber hose to hold in place as shown in Figure 20.
12. Test for leaks. Any and all leaks should be repaired before proceeding with installation. When testing with air or some other gas, it might be necessary to tighten stem packing nuts on some valves to maintain air pressure in the riser. Pressure testing risers with water should be done with the unit service valves closed to prevent flushing debris into the unit valve packages. These valves will also allow risers to be drained down after testing in the winter to avoid freeze-up problems. In the event that leaking or defective components are discovered, the sales representative must be notified **BEFORE** any repairs are attempted. All leaks should be repaired before proceeding with the unit installation.
13. After system integrity has been established, the riser insulation must be pulled back into place over the joint and glued or sealed to prevent sweating and heat loss

Modular Hi-Rise Series Fan Coils

INSTALLATION, OPERATION, & MAINTENANCE MANUAL

or gain. All of the risers including the riser stubouts should be properly covered with insulation. Internally mounted chilled water piping and valves are located over the drain pan and need not be insulated.

Any fireproofing requirements where risers or piping penetrate floors or walls are the responsibility of the installer. This work should be done only after all pressure testing is completed. The fireproofing method used must accommodate pipe expansion and contraction and the piping must be protected from abrasion and chemical attack. The pipe insulation also must be maintained to prevent sweating and must be protected from wear or erosion at the joint between the insulation and the fireproofing material.

When no risers are ordered for the Mega Modular unit, it is the responsibility of the installer to make sure that a field supplied isolation ball valve is installed between each supply and return piping connection to the unit. Flare fittings are factory provided to allow connection between the ball valves and the hoses.

Variations in floor-to-floor dimensions may require field work such as cutting off or extending the risers. This operation is the responsibility of the installer. The riser joint filler material must be selected to withstand the total operating pressure (both static and pumping head) to which the system will be subjected. Low temperature lead alloy solders such as "50/50" and "60/40" are normally not suitable.

Chilled water and hot water risers should never be piped to drain down into the condensate riser. Extensive water damage can occur due to drain overflow. Drain chilled and hot water risers to a remote location away from the unit such as sink, room and floor drains.

All installations should be made in compliance with all governing codes and ordinances. **Compliance with all codes is the responsibility of the installing contractor.**

Unit Knockout Locations (Typical)

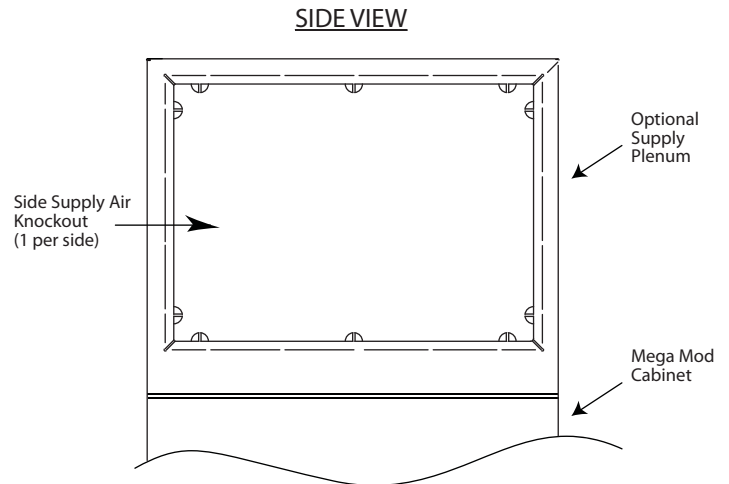

Figure 21

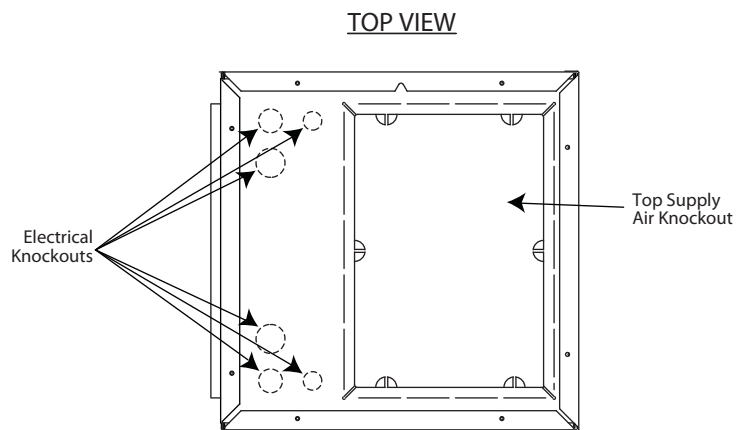

Figure 22

Supply Air Installation

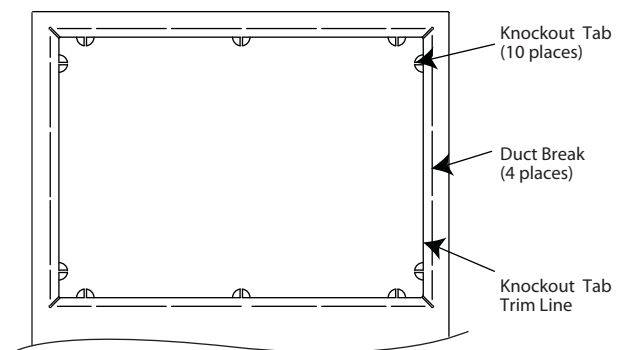

Figure 23

1. If the unit has been ordered with a supply air plenum, then each side of the unit has one supply air knockout as well as a supply air knockout on the top of the unit (see Figures 21 and 22).
2. Determine which supply air opening/openings are required for your application.
NOTE: The supply air opening on the riser side of the unit should not be used.
3. Use a sharp retractable knife to trim insulation using center knockout slot/trim line as pattern (see Figure 23).
4. Use a sharp standard needle nose pliers and grab knockout tab (see Figure 23).
5. Twist or pry pliers back and forth until knockout tab breaks away from unit.
6. Repeat for all supply air tabs until all have been broken.
7. Discard center knockout piece. Be careful of sharp edges.
8. Use a sharp retractable knife to trim any excess insulation using knockout hole as pattern.

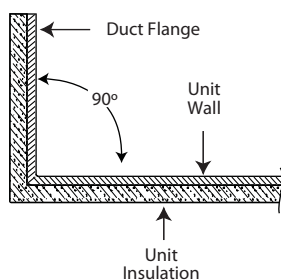

Figure 24

9. Use duct pliers (hand seamers) to fold duct flange out of the unit 90° for each side of the supply air opening along duct break (see Figure 23). The 90° flanges can now be used as drywall stops to prevent coverage of discharge opening (see Figure 24).
10. Use adhesive or glue to re-attach insulation that has pulled away from the unit during knockout removal process.
11. For ducted applications tape should be applied along and around all of the supply air opening knockouts to prevent air leakage.

SECTION III – Finishing Installation (All Models)

Grille/Ductwork Installation

All ductwork and/or supply and return grilles should be installed in accordance with the project plans and specifications. If not included on the unit or furnished from the factory, supply and return grilles should be provided as recommended in the product catalog.

Outside Air Installation (if required)

Units provided with outside air for ventilation should have some form of low-temperature protection to prevent coil freeze-up. This protection may be any of several methods such as a low-temperature thermostat to close the outside air damper or a preheat coil to temper the outside air before it reaches the unit.

It should be noted that none of these methods will adequately protect a coil in the event of power failure. The safest method of freeze protection is to use glycol in the proper percent solution for the coldest expected air temperature.

The manufacturer assumes no responsibility for undesirable system operation due to improper system design, equipment or component selection, and/or installation of ductwork, grilles, and other related components.

Electrical Connections

The unit serial plate lists the unit electrical characteristics such as the required supply voltage, fan and heater amperage and required circuit ampacities. The unit wiring diagram shows all unit and field wiring. Since each project is different and each unit on a project may be different, the installer must be familiar with the wiring diagram and serial plate on the unit **BEFORE** beginning any wiring.

The unit electrical supply is designed to enter through knockouts provided in the top of the unit and pass down through matching knockouts in the control section top.

Modular Hi-Rise Series Fan Coils

INSTALLATION, OPERATION, & MAINTENANCE MANUAL

Where space allows, power may be pulled directly through the side of the cabinet into the control section.

All components furnished for field installation by either the factory or the controls contractor should be located and checked for proper function and compatibility. All internal components should be checked for shipping damage, and any loose connections should be tightened to minimize problems during start-up.

Any devices such as fan switches or thermostats that have been furnished from the factory for field installation must be wired in strict accordance with the wiring diagram that appears on the unit. Failure to do so could result in personal injury or damage to components, and will void all manufacturer's warranties.

The fan motor should never be controlled by any wiring or device other than the factory-furnished switch or thermostat/switch combination without factory authorization. Fan motor(s) may be temporarily wired for use during construction only with prior factory approval in strict accordance with the instructions issued at that time.

All field wiring should be done in accordance with governing codes and ordinances. Any modification of the unit wiring without factory authorization will void all of the factory warranties and will nullify any agency listings.

The manufacturer assumes no responsibility for any damages and/or injuries resulting from improper field installation and/or wiring.

Exposed Unit Touch-up and Repainting

Return access and exposed cabinet units may be furnished with a baked enamel finish. Small scratches in this finish may be repaired with touch-up paint available from the factory. Some colors of touch-up paint are available in aerosol containers and all touch-up paint is available in pint, quart, and gallon cans. Contact the factory for availability.

Proper safety procedures should be followed regarding ventilation and safety equipment. The manufacturer's directions should be followed for the products being used.

To repaint the factory-baked enamel, the finish should be prepared by light sanding with #280 grit sand paper or #000 or #0000 fine steel wool. The surface may also be wiped with a liquid surface etch cleaning product such as "No Sand" or "Pasceo." These items should be available at most paint product stores. It should be noted that the more conscientiously this preparation is done, the more effective it will be.

After this preparation is accomplished, the factory finish should provide excellent adhesion for a variety of air-dried top coats. Enamel will give a more durable, higher gloss finish, while latex will not adhere as well and will give a dull, softer finish. Top coats involving an exothermic chemical process between two components, such as epoxies and urethanes, should be avoided.

Factory aerosol touch-up paint may require a number of light "dust coats" to isolate the factory-baked enamel finish from the quick drying touch-up paint.

Concealed Unit Enclosure

Concealed units are designed to have gypsum board or other types of wall board applied directly to the unit cabinet surface to a maximum combined thickness of 5/8-inch. The wall board may be attached with drywall screws or similar fasteners provided they penetrate the cabinet no more than 1/2 an inch. These fasteners must be located to avoid damage to internal components and wiring in the same manner as the anchoring fasteners. When applying the wall board directly to the unit cabinet, it may be necessary to shim the wall board in some areas to achieve the desired finished wall surface.

An alternate method of enclosing the unit is to frame one or more sides with studding and apply the wall board to this framing. This method requires specific unit features and return access panels when used on the return-air side of a unit. Units not properly equipped will exhibit poor cooling and/or heating performance and could experience excessive or premature component failures.

Contact the sales representative or the factory with any questions regarding unit enclosure methods.

SECTION IV – Start-up (All Models)

Before beginning any start-up operation, the start-up personnel should familiarize themselves with the unit, options and accessories, and control sequence to understand the proper system operation. All personnel should have a good working knowledge of general start-up procedures and have the appropriate start-up and balancing guides available for consultation.

The building must be completely finished including doors, windows, and insulation. All internal walls and doors should be in place and in the normal position. In some cases the interior decorations and furniture may influence overall system performance. The entire building should be as complete as possible before beginning any system balancing.

The initial step in any start-up operation should be a final visual inspection. All equipment, plenums, duct-work, and piping should be inspected to verify that all systems are complete and properly installed and mounted, and that no debris or foreign articles such as paper or drink cans are left in the units or other areas.

Each unit should be checked for loose wires, free blower wheel operation, and loose or missing access panels or doors. Except as required during start-up and balancing operations, no fan coil units should be operated without all the proper ductwork attached, supply and return grilles in place, and all access doors and panels in place and secure. A clean filter of the proper size and type must also be installed. Failure to do so could result in damage to the equipment or building and furnishings and/or void all manufacturer's warranties.

Cooling/Heating System

Prior to the water system start-up and balancing, the chilled/hot water systems should be flushed to clean out dirt and debris which may have collected in the piping during construction. During this procedure, the system should be flushed from the supply riser to the return riser through a cross-over loop at the end of the riser column, and all unit service valves must be in the closed position. This prevents foreign matter from entering the unit and clogging the

valves and metering devices. Strainers should be installed in the piping mains to prevent this material from entering the units during normal operation.

During system filling, air venting from the unit is accomplished by the use of the standard, manual air vent fitting, or the optional, automatic air vent fitting installed on the coil. Venting can be accomplished by depressing the needle valve core. Automatic air vents may be unscrewed one turn counterclockwise to speed initial venting, but should be screwed in for automatic venting after start-up operations.



CAUTION: The air vent provided on the unit is not intended to replace the main system air vents and may not release air trapped in other parts of the system. Inspect the entire system for potential air traps and vent those areas as required, independently. In addition, some systems may require repeated venting over a period of time to properly eliminate air from the system.

Air System Balancing

All duct stubs, grilles, filters, and return-access panels must be properly installed to establish actual system operating conditions **BEFORE** beginning air balancing operations.

Each individual unit and the attached ductwork is a unique system with its own operating characteristics. For this reason, air balancing is normally done by balance specialists who are familiar with all procedures required to properly establish air distribution and fan-system operating conditions. These procedures should not be attempted by unqualified personnel.

Units with no ductwork have air volumes predetermined at the factory by supply grille size and normally do not require air balancing other than selecting the desired fan speed. Units furnished with optional dampers on supply grilles may require some small adjustments to "fine tune" the air delivery to each grille. Opposed blade balancing dampers are not available for all grilles on a unit with electric heat.

Modular Hi-Rise Series Fan Coils

INSTALLATION, OPERATION, & MAINTENANCE MANUAL

After proper system operation is established, the actual unit air delivery and the actual fan motor amperage draw for each unit should be recorded in a convenient place for future reference.

ECM Blower

If the unit is equipped with an ECM blower, additional steps may be required during the air balancing process. The ECM blower is controlled by one of three control boards, depending on the options ordered with the unit.

Review project submittals or order acknowledgement to determine which ECM control scheme the unit has. Alternatively, match the control board to the illustrations identified in the sections below.

Jumper

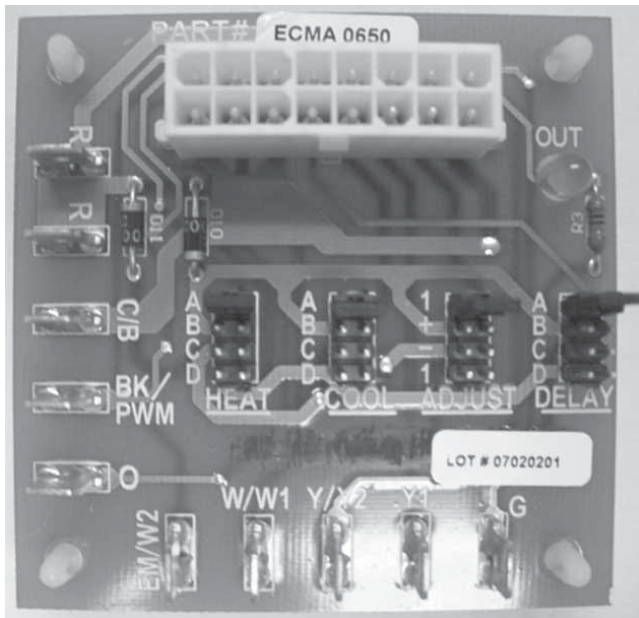

Figure 25–Jumper Board

The unit has been factory configured to produce PSC equivalent airflow on high speed, with medium and low speed set at 80% and 60% of high, respectively. If these settings are acceptable, then no further configuring is required.

To adjust airflow, relocate board mounted jumpers as indicated on configuration chart. Chart is located on control box cover.



CAUTION: Both of the procedures described below require the control box to be powered while adjustments are made. Line voltage components are concealed behind a secondary cover. However, installer should still take all reasonable precautions.

Rheostat

The unit has been factory configured to produce PSC equivalent airflow on high speed, with medium and low speed set at 80% and 60% of high, respectively. If these settings are acceptable, then no further configuring is required.

Board mounted rheostats are provided to adjust the airflow pertaining to each output. Each output can be adjusted from 0 to 100% of the motor's factory programmed operating range. To set airflow, connect a volt-meter between "common" (near the red status LED) and Flo1 – Flo4.

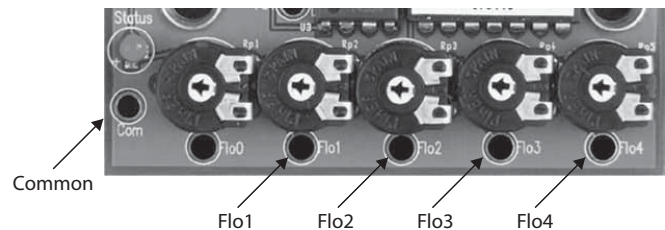

Figure 26–Rheostat Board

IEC's convention is to preset and wire Flo1 for high speed, Flo2 for medium, and Flo3 for low. Flo4 is not used with any standard thermostat, but may be employed for a more advanced application. The chart on the control box cover associates airflow rates with the voltage indicated on your volt-meter. For each speed, adjust the rheostat until indicated voltage matches the desired value from the airflow table.

Modular Hi-Rise Series Fan Coils

INSTALLATION, OPERATION, & MAINTENANCE MANUAL

Proportional

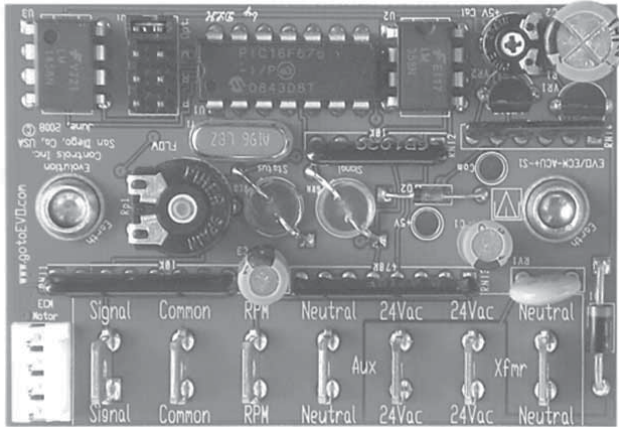

Figure 27—Proportional Board

If a factory provided thermostat or DDC controller is utilized, then the unit is already correctly configured. A field furnished thermostat or control may require adjustment of board jumpers.

Jumper	Removed	Installed
P	0-10VDC input, fan enabled and disabled by switching power to ACU+	2-10VDC or 4-20mA input, fan disabled by control voltage dropping below 2V
M	No controller	Controller providing fan signal
R	Standard	Airflow knob correct for access from component side of board

Table 1

IEC recommends using the specified thermostat or DDC controller to commission the unit whenever possible. However, the blower can be started and operated without the thermostat. To do so, locate the airflow adjustment screw which is accessible from the inside of the control box. With service switch in the “ON” position, turn the adjustment screw. The unit has now been placed in manual override. Manual override will expire when one of the following conditions is satisfied:

- Power to the unit is cycled
- 15 min. elapses with no change to adjustment screw
- Unit receives a control signal from the thermostat or controller

Water Treatment

Proper water treatment is a specialized industry. IEC recommends consulting an expert in this field to analyze the water for compliance with the water quality parameters listed below, and to specify the appropriate water treatment regimen. The expert may recommend typical additives such as rust inhibitors, scaling preventative, antimicrobial growth agents, or algae preventatives. Anti-freeze solutions may also be used to lower the freezing point.

IEC water coil tubes and headers are constructed of pure copper. Multiple brass alloys may be present in the valve package, depending on unit configuration. It is the user's responsibility to ensure the tube and piping materials furnished by IEC, are compatible with the treated water.

Failure to provide proper water quality will void the fan coil unit's warranty.

Water Containing	Required Concentration
Sulphate	Less than 200 ppm
pH	7.0 – 8.5
Chlorides	Less than 200 ppm
Nitrate	Less than 100 ppm
Iron	Less than 4.5 mg/l
Ammonia	Less than 2.0 mg/l
Manganese	Less than 0.1 mg/l
Dissolved Solids	Less than 1000 mg/l
CaCO ₃ Hardness	300 - 500 ppm
CaCO ₃ Alkalinity	300 - 500 ppm
Particulate Quantity	Less than 10 ppm
Particulate Size	800 micron max

Water System Balancing

A complete knowledge of the hydronic system, along with its components and controls, is essential to proper water system balancing. This procedure should not be attempted by unqualified personnel. The system must be complete, and all components must be in operating condition **BEFORE** beginning water system balancing operations.

Each hydronic system has different operating characteristics depending on the devices and controls used in the system.

Modular Hi-Rise Series Fan Coils

INSTALLATION, OPERATION, & MAINTENANCE MANUAL

The actual balancing technique may vary from one system to another.

After the proper system operation is established, the appropriate system operating conditions such as various water temperatures and flow rates should be recorded in a convenient place for future reference.

Before and during water system balancing, conditions may exist due to incorrect system pressures which may result in noticeable water noise or undesired valve operation. After the entire system is balanced, these conditions will not exist on properly designed systems.

Controls Operation

Before proper control operation can be verified, all other systems must be operating properly. The correct water and air temperatures must be present for the control function being tested. Some controls and features are designed to not operate under certain conditions. For example, on a two-pipe cooling/heating system with auxiliary electric heat, the electric heater cannot be energized with hot water in the system.

A wide range of controls, electrical options and accessories may be used with the equipment covered in this manual. Consult the approved unit submittals, order acknowledgements, and other literature for detailed information regarding each individual unit and its controls. Since controls and features may vary from one unit to another, care should be taken to identify the controls used on each unit and their proper control sequence. Information provided by component manufacturers regarding installation, operation, and maintenance of their individual controls is available upon request.

When changing from one mode to another (cooling to heating or heating to cooling), it may take some time to actually notice a change in the leaving air temperature. In addition, some units may be designed for a very low air temperature rise in heating. Before declaring a unit inoperative or a component defective, it may be necessary to verify operation by more than one method.

SECTION V – Routine Maintenance (All Models)

Each unit on a job will have its own unique operating environment and conditions which may dictate a maintenance schedule that differs from other units on a job. A formal schedule of regular maintenance and an individual unit log should be established and maintained. This will help to achieve the maximum performance and service life of each unit on the job.

Information regarding safety precautions contained in the preface at the beginning of this manual should be followed during any service and maintenance operations.

For more detailed information concerning service operations consult your sales representative or the factory.

Motor/Blower Assembly

The type of fan operation is determined by the control components and their method of wiring. This may vary from unit to unit. Refer to the wiring diagram that is attached to each unit for that unit's individual operating characteristics.

All motors have permanently lubricated bearings. No field lubrication is required.

Should the assembly require more extensive service, the motor/blower assembly may be removed from the unit to facilitate such operations as motor or blower wheel/housing replacement, etc.

Dirt and dust should not be allowed to accumulate on the blower wheel or housing. This can result in an unbalanced blower wheel condition which can damage a blower wheel or motor. The wheel and housing may be cleaned periodically using a vacuum cleaner and a brush taking care not to dislodge the factory balancing weights on the blower wheel blades.

Coil

Coils may be cleaned by removing the filter and brushing the entering air face between fins with a stiff brush. Care should be taken to not damage coil fins. Brushing should be

followed by cleaning with a vacuum cleaner. If a compressed air source is available, the coil may also be cleaned by blowing air through the coil fins from the leaving air face. This should again be followed by vacuuming. Units provided with the proper type of air filters, replaced regularly, will require less frequent coil cleaning.

Electric Resistance Heater Assembly

Electric resistance heaters typically require no normal periodic maintenance when unit air filters are changed properly. The operation and service life may be affected by other conditions and equipment in the system. The two most important operating conditions for an electric heater are proper air flow and proper supply voltage. High supply voltage and/or poorly distributed or insufficient air flow over the element will result in element overheating. This condition may result in the heater cycling on the high-limit thermal cutout. The high-limit thermal cutout device is a safety device only and is not intended for continuous operation. With proper unit application and operation, the high-limit thermal cutout will not operate. This device only operates when a problem exists, and **ANY** condition that causes high-limit cutout **MUST** be corrected immediately. High supply voltage also causes excessive amperage draw and may trip the circuit breaker or blow the fuses on the incoming power supply.

After proper air flow and supply power are assured, regular filter maintenance is important to provide clean air over the heater. Dirt that is allowed to deposit on the heating element will cause hot spots and eventual element burn through. These hot spots will normally not be enough to trip the high-limit thermal cutout device and may not be evident until actual heater element failure.

Electrical Wiring and Controls

The electrical operation of each unit is determined by the components and wiring of the unit. This may vary from unit to unit. Consult the wiring diagram attached to the unit for the actual type and number of controls provided on each unit.

The integrity of all electrical connections should be verified at least twice during the first year of operation.

Afterwards, all controls should be inspected regularly for proper operation. Some components may experience erratic operation or failure due to age. Wall thermostats may also become clogged with dust and lint and should be periodically inspected and cleaned to provide reliable operation.

When replacing any components such as fuses, contractors, or relays, use only the exact type, size and voltage component as furnished from the factory. Any deviation without factory authorization could result in personal injury or damage to the unit. This will also void all factory warranties. All repair work should be done in such a manner as to maintain the equipment in compliance with governing codes, ordinances and testing agency listings.

More specific information regarding the use and operating characteristics of the standard controls offered by the manufacturer are contained in other manuals.

Valves and Piping

No formal maintenance is required on the valve-package components most commonly used with fan coil units other than a visual inspection for possible leaks in the course of other normal periodic maintenance. In the event that a valve should need replacement, the same precautions taken during the initial installation to protect the valve package from excessive heat should also be used during replacement.

Filters, Throwaway

The type of throwaway filter most commonly used on fan coil units should be replaced on a regular basis. The time interval between each replacement should be established based on regular inspection of the filter and should be recorded in the log for each unit. Refer to the product catalog for the recommended filter size for each product type and size. If the replacement filters are not purchased from the factory, the filters used should be the same type and size as those furnished from or recommended by the factory. Pleated media or extended surface filters should not be used since the high air pressure drops encountered with these types of filters are not compatible with the type

Modular Hi-Rise Series Fan Coils

INSTALLATION, OPERATION, & MAINTENANCE MANUAL

of fan coil unit covered in this manual. Consult the factory for applications using filter types other than the factory standard or optional product.

Filters, Permanent

A maintenance schedule for permanent filters should be developed in the same manner as throwaway filters. Unlike throwaway filters, permanent filters may be cleaned and re-installed in the unit instead of being discarded when dirty. The optional factory permanent filter may be cleaned in hot soapy water to remove any trapped dirt. It should then be set aside on edge to dry.

Before replacing the filter in the unit, it should be recharged with some type of entrapment film such as "Film-Cor Recharging Oil." The filter should be sprayed on both sides or submerged in the film to assure complete coverage. The filter should not be allowed to soak in the film, but should be immediately removed and the excess film drained from the filter before re-installation in the unit. Consult a local filter supplier for types of available cleaning solutions and charging films.

It should be noted that permanent filters normally have less static pressure loss than throwaway filters.

Drain

The drain should be checked before initial start-up and at the beginning of each cooling season to assure that the drain trap and riser are clear. If it is clogged, steps should be taken to clear the debris so that condensate will flow easily.

Periodic checks of the drain should be made during the cooling season to maintain a free-flowing condensate.

Should the growth of algae and/or bacteria be a concern, consult an air conditioning and refrigeration supply organization familiar with local conditions for chemicals or other solutions available to control these agents.

Replacement Parts

Factory replacement parts should be used wherever possible to maintain unit performance, its normal operating characteristics, and the testing agency listings. Replacement parts may be purchased through a local sales representative.

Should replacement parts not be purchased from the factory, use only parts duplicating the exact type, size, voltage, and other operating characteristics of the original part.

Contact the local sales representative or the factory before attempting any unit modifications. Any modifications not authorized by the factory could result in personal injury, damage to the unit, and could void all factory warranties.

When ordering parts, the following information must be supplied to ensure proper part identification:

- (1) Complete unit model number
- (2) Unit serial number
- (3) Unit hand connection (right or left hand)
- (4) Complete part description including any numbers

On warranty replacements, in addition to the information previously listed, the unit shipping code which appears on the upper right-hand corner of the serial plate is required. Contact the factory for authorization to return any parts such as defective parts replaced in warranty. All shipments returned to the factory must be marked with a Return Authorization Number which is provided by the factory.

All equipment and components sold through the Parts Department are warranted under the same conditions as the standard manufacturer's warranty with the exception that the warranty period is twelve (12) months unless the component is furnished as a warranty replacement. Parts furnished as warranty replacements are warranted for the remaining term of the original unit warranty, or not less than thirty (30) days.

SECTION VI – Checklists

Receiving and Inspection

- Unit received undamaged
- Unit received complete as ordered
- “Furnish only” parts accounted for
- Unit arrangement/hand correct
- Unit structural support complete and correct

Handling and Installation

- Mounting grommets/isolators used
- Unit mounted level and square
- Proper access provided for unit and accessories
- Proper electrical service provided
- Proper overcurrent protection provided
- Proper service switch/disconnect provided
- Proper chilled water line size to unit
- Proper hot water line size to unit
- All services to unit in code compliance
- All shipping screws and braces removed
- Unit protected from dirt and foreign matter

Cooling/Heating Connections

- Protect valve package components from heat
- Connect field piping to unit
- Pressure test all piping for leaks
- Install drain line and traps, as required
- Insulate all piping, as required
- Connect risers from MM models to MS models
- Connect risers to unit coil valve package
(If risers are shipped/installed separately)

Ductwork Connections

- Install ductwork, fittings and grilles, as required
- Flexible duct connections at unit
- Proper supply and return grille type and size
- Control outside air for freeze protection
- Insulate all ductwork, as required

Electrical Connections

- Refer to unit wiring diagram
- Connect incoming power service or services
- Install and connect “furnish only” parts

Unit Start-up

- General visual unit and system inspection
- Check for proper fan rotation
- Record electrical supply voltage
- Check all wiring for secure connections
- Close all unit isolation valves
- Flush water systems
- Fill systems with water/refrigerant
- Vent water systems, as required
- All ductwork and grilles in place
- All unit panels and filters in place
- Start fans, pumps, chillers, etc.
- Check for overload conditions of all units
- Check all ductwork and units for air leaks
- Balance water systems, as required
- Balance air systems, as required
- Record all final settings for future use
- Check piping and ductwall for vibration
- Check all dampers for proper operation
- Verify proper cooling operation
- Verify proper heating operation
- Reinstall all covers and access panels
- Verify proper condensate drainage

Modular Hi-Rise Series Fan Coils

INSTALLATION, OPERATION, & MAINTENANCE MANUAL

TERMS AND CONDITIONS

- Orders shall not be binding upon International Environmental Corporation, an Oklahoma corporation (hereinafter referred to as "IEC") unless accepted by an authorized representative of IEC at its office in Oklahoma City, Oklahoma. No distributor, sales representative or any other person or entity (except authorized employees of IEC at its office in Oklahoma City, Oklahoma) has any authority whatsoever to bind IEC to any representation or agreement of any kind.
- IEC does not build items to plans and specifications. IEC agrees to furnish only the items as described in IEC's acknowledgment unless IEC's office in Oklahoma City, Oklahoma has previously received and accepted, in writing, approved submittals from Purchaser.
- Prices acknowledged are firm only if Purchaser releases the goods covered by this order for immediate production by IEC within sixty (60) days from the date of Purchaser's initial offer to purchase and for shipment by IEC within IEC's estimated shipping date, unless otherwise agreed to in writing by IEC at its office in Oklahoma City, Oklahoma. If Purchaser does not meet the terms and conditions of this paragraph, the prices are subject to escalation to those prices in effect at time of shipment without notice to Purchaser.
- All prices are F.O.B. IEC's factory, unless otherwise agreed by IEC in writing; and, all payments and prices shall be in U.S.A. dollars.
- If goods are released for production but IEC is prevented by the Purchaser from shipping upon completion or by IEC's estimated shipping date, whichever is later, IEC may at its option, in addition to all other remedies, invoice Purchaser to be payable within thirty (30) days and store the goods at Purchaser's sole expense.
- Title to and risk of loss to the goods passes to the Purchaser F.O.B. IEC's factory.
- Disclaimer**

It is expressly understood that unless a statement is specifically identified as a warranty, statements made by IEC or its representatives relating to IEC's products, whether oral, written or contained in any sales literature, catalog or any other agreement, are not express warranties and do not form a part of the basis of the bargain, but are merely IEC's opinion or commendation of IEC's products. **EXCEPT AS SPECIFICALLY SET FORTH HEREIN, THERE IS NO EXPRESS WARRANTY AS TO ANY OF IEC'S PRODUCTS. IEC MAKES NO WARRANTY AGAINST LATENT DEFECTS. IEC MAKES NO WARRANTY OF MERCHANTABILITY OF THE GOODS OR OF THE FITNESS OF THE GOODS FOR ANY PARTICULAR PURPOSE.**
- Grant of Limited Express Warranty**

IEC warrants IEC products purchased and retained in the United States of America and Canada to be free from defects in material and workmanship under normal use and maintenance as follows: (1) All complete fan coil units built or sold by IEC for twelve (12) months from date of unit start up or eighteen (18) months from date of shipment (from factory), whichever comes first.

All parts must be returned to IEC's factory in Oklahoma City, Oklahoma, freight prepaid, no later than sixty (60) days after the date of the failure of the part; if IEC determines the part to be defective and within IEC's Limited Express Warranty, IEC shall, when such part has been either replaced or repaired, return such to a factory recognized contractor or service organization, F.O.B. IEC's factory, Oklahoma City, Oklahoma, freight prepaid. The warranty on any parts repaired or replaced under warranty expires at the end of the original warranty period. For information and warranty service contact:

International Environmental Corporation
Customer Service
5000 West I-40
Oklahoma City, OK 73128
(405) 605-5000

This warranty does not cover and does not apply to: (1) Air filters, fuses, fluids; (2) Products relocated after initial installation; (3) Any portion or component of any system that is not supplied by IEC, regardless of the cause of the failure of such portion or component; (4) Products on which the unit identification tags or labels have been removed or defaced; (5) Products on which payment to IEC is or has been in default; (6) Products which have defects or damage which result from improper installation, wiring, electrical imbalance characteristics or maintenance; or are caused by accident, misuse or abuse, fire, flood, alteration or misapplication of the product; (7) Products which have defects or damage which result from a contaminated or corrosive air or liquid supply or operation at abnormal temperatures; (8) Mold, fungus or bacteria damages; (9) Products subjected to corrosion or abrasion; (10) Products manufactured or supplied by others; (11) Products which have been subjected to misuse, negligence or accidents; (12) Products which have been operated in a manner contrary to IEC's printed instructions; or (13) Products which have defects, damage or insufficient performance as a result of insufficient or incorrect system design or the improper application of IEC's products.

IEC is not responsible for: (1) The cost of any fluids or other system components, or associated labor to repair or replace the same, which is incurred as a result of a defective part covered by IEC's Limited Express Warranty; (2) The costs of labor, materials or service incurred in removal of the defective part, or in obtaining and replacing the new or repaired part; or, (3) Transportation costs of the defective part from the installation site to IEC or of the return of any part not covered by IEC's Limited Express Warranty.

Limitation: This Limited Express Warranty is given in lieu of all other warranties. If, notwithstanding the disclaimers contained herein, it is determined that other warranties exist, any such warranties, including without limitation any express warranties or any implied warranties of fitness for particular purpose and merchantability, shall be limited to the duration of the Limited Express Warranty.
- Limitation of Remedies**

In the event of a breach of the Limited Express Warranty, IEC will only be obligated at IEC's option to repair the failed part or unit or to furnish a new or rebuilt part or unit in exchange for the part or unit which has failed. If after written notice to IEC's factory in Oklahoma City, Oklahoma of each defect, malfunction or other failure and a reasonable number of attempts by IEC to correct the defect, malfunction or other failure and the remedy fails of its essential purpose, IEC shall refund the purchase price paid to IEC in exchange for the return of the sold good(s). Said refund shall be the maximum liability of IEC. **THIS REMEDY IS THE SOLE AND EXCLUSIVE REMEDY OF THE BUYER OR THEIR PURCHASER AGAINST IEC FOR BREACH OF CONTRACT, FOR BREACH OF ANY WARRANTY OR FOR IEC'S NEGLIGENCE OR IN STRICT LIABILITY.**
- Limitation of Liability**

IEC shall have no liability for any damages if IEC's performance is delayed for any reason or is prevented to any extent by any event such as, but not limited to: any war, civil unrest, government restrictions or restraints, strikes, or work stoppages, fire, flood, accident, shortages of transportation, fuel, material or labor, acts of God or any other reason beyond the sole control of IEC. **IEC EXPRESSLY DISCLAIMS AND EXCLUDES ANY LIABILITY FOR CONSEQUENTIAL OR INCIDENTAL DAMAGE IN CONTRACT, FOR BREACH OF ANY EXPRESS OR IMPLIED WARRANTY, OR IN TORT, WHETHER FOR IEC'S NEGLIGENCE OR AS STRICT LIABILITY.**
- IEC shall have no system design, application or maintenance responsibility or responsibility for mold, fungus or bacteria to Purchaser or any other third party.
- All sales, goods and services, use, excise, value added, transportation, privilege, occupational consumption, storage, document, transaction or other taxes which may be levied by any taxing authority as a result of this transaction shall be paid by the Purchaser.
- Unless otherwise agreed to in writing by IEC any technical data furnished in conjunction with this order and not obtainable from another source shall not be duplicated, used, or disclosed in whole or in part for any purpose other than to evaluate this order.
- IEC shall have no liability or other obligation hereunder, if IEC's performance is delayed for any reason or is prevented to any extent by any event such as, but not limited to: any act of God, strike or work stoppage, fire, flood, accident, allocation, or other controls of Government authorities, shortages of transportation, fuel, material or labor, or any other cause beyond IEC's sole control. Any shipping date stated by IEC is IEC's best estimate but IEC makes no guarantee of shipment by any such date and shall have no liability or other obligation for failure to ship on such date, regardless of cause.
- Payment terms are net thirty (30) days from date of shipment on approved credit. One and one half percent (1 1/2%) per month (18% annual rate) may be charged on past due accounts or the highest rate permitted by applicable law, whichever is lesser. In the event the account is placed for collection, Purchaser shall be responsible for all reasonable attorneys fees or costs on a solicitor and client basis, plus all other costs and expenses incurred by IEC in securing payment.
- Purchaser shall not cancel the contract without prior written consent of an authorized representative of IEC at its offices in Oklahoma City, Oklahoma. In the event Purchaser cancels the contract with the prior written consent of IEC after the Purchaser's offer to purchase is received and acknowledged in writing, IEC shall be entitled to receive from Purchaser IEC's cost incurred to time of cancellation plus a reasonable allowance for overhead and profit.
- Purchaser shall not assign any of its interest or rights under this agreement without written consent of IEC.
- IEC will protect all its lien rights. IEC will not furnish lien waivers or releases until IEC receives payment, in full, at its office in Oklahoma City, Oklahoma from Purchaser for the goods covered by this order. There is no authorized retainage for any reason.
- This Agreement shall be construed, and the rights and liabilities of the parties hereunder shall be determined in accordance with the laws of the State of Oklahoma. If it shall be found that any portion of this agreement violates any particular law of the United States or any state in the United States having jurisdiction or, if applicable, any law of Canada or any province or territory in Canada having jurisdiction, such portion of the agreement shall be of no force and effect in that political unit, division or sub-division in which they are illegal or unenforceable and the agreement shall be treated as if such portion or portions had not been inserted. In the event that any dispute or disagreement in connection with any order should arise or exist between Purchaser and IEC, jurisdiction and venue for any legal action shall be, if IEC so elects, exclusively in the state or federal courts in Oklahoma County, Oklahoma. The statute of limitations on any claim of the Purchaser against the IEC shall be one (1) year from the date the cause of action accrues.
- Without regard to any other agreement, all obligations of Purchaser to IEC shall become immediately due and payable if Purchaser becomes insolvent or if Purchaser does not make payments when due or breaches any other agreement or fails to perform any obligation.
- All orders are expressly limited and made conditional upon acceptance by Purchaser of the terms and conditions set forth above without change. There shall be no understandings, agreements, or obligations (outside these terms and conditions) unless specifically set forth in writing and accepted by signature of an authorized representative of IEC in Oklahoma City, Oklahoma.
- The parties hereto have requested that these presents and all judicial proceedings relating thereto be drafted in English. Les parties aux présentes ont demandé à ce que les présentes et toutes procédures judiciaires y afférentes soient rédigées en anglais

Modular Hi-Rise Series Fan Coils

INSTALLATION, OPERATION, & MAINTENANCE MANUAL

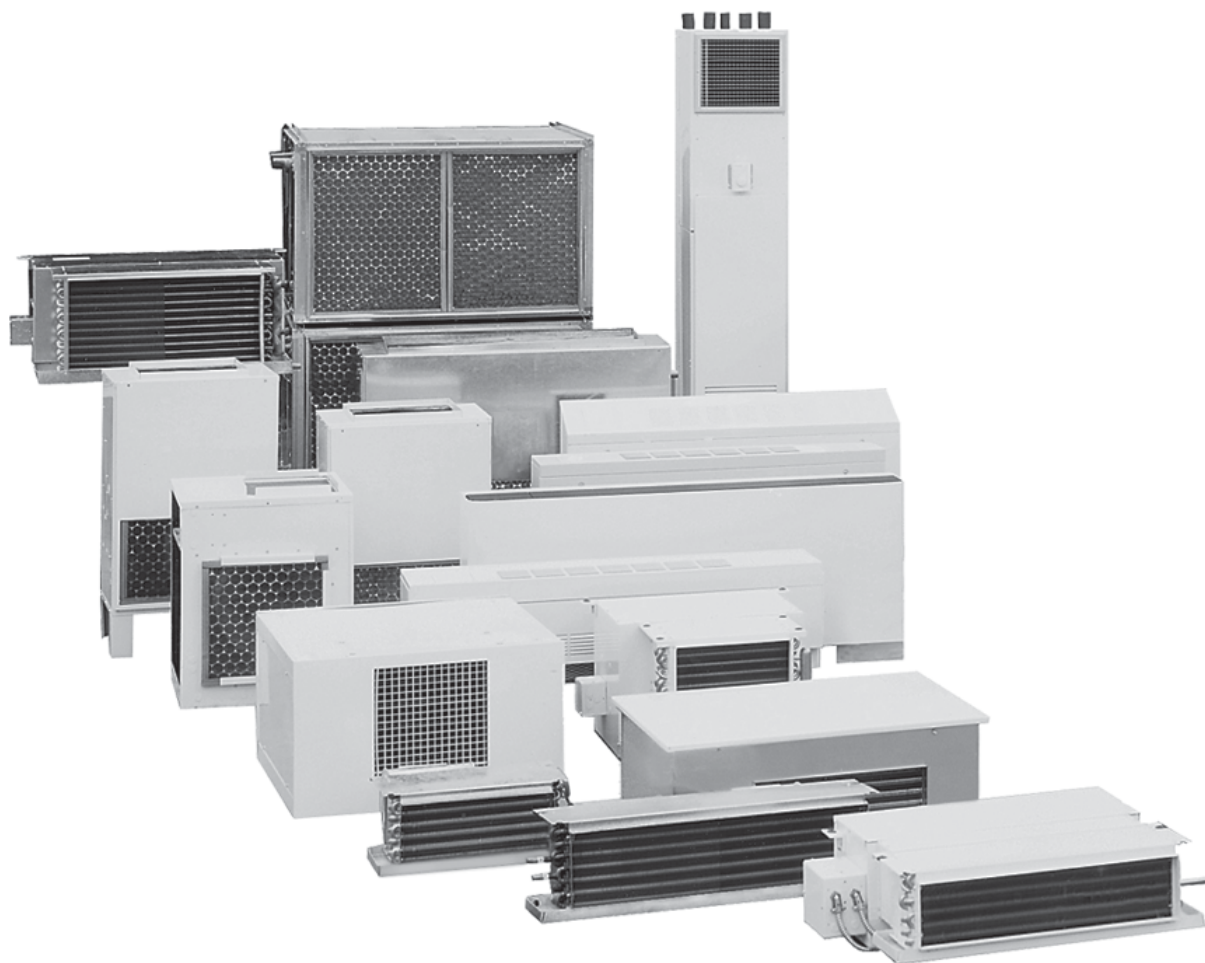

IEC Modular Hi-Rise IOM Part Number: I100-90001407

IOM-051 Revision 7

©2012 International Environmental Corporation (IEC)

IEC is a subsidiary of LSB Industries, Inc.

NYSE symbol LXU; www.lsb-okc.com

P.O. Box 2598
Oklahoma City, OK 73101-2598
p: 405.605.5000
f: 405.605.5001
www.iec-okc.com