

Belt Drive Series Fan Coils

INSTALLATION, OPERATION, & MAINTENANCE MANUAL

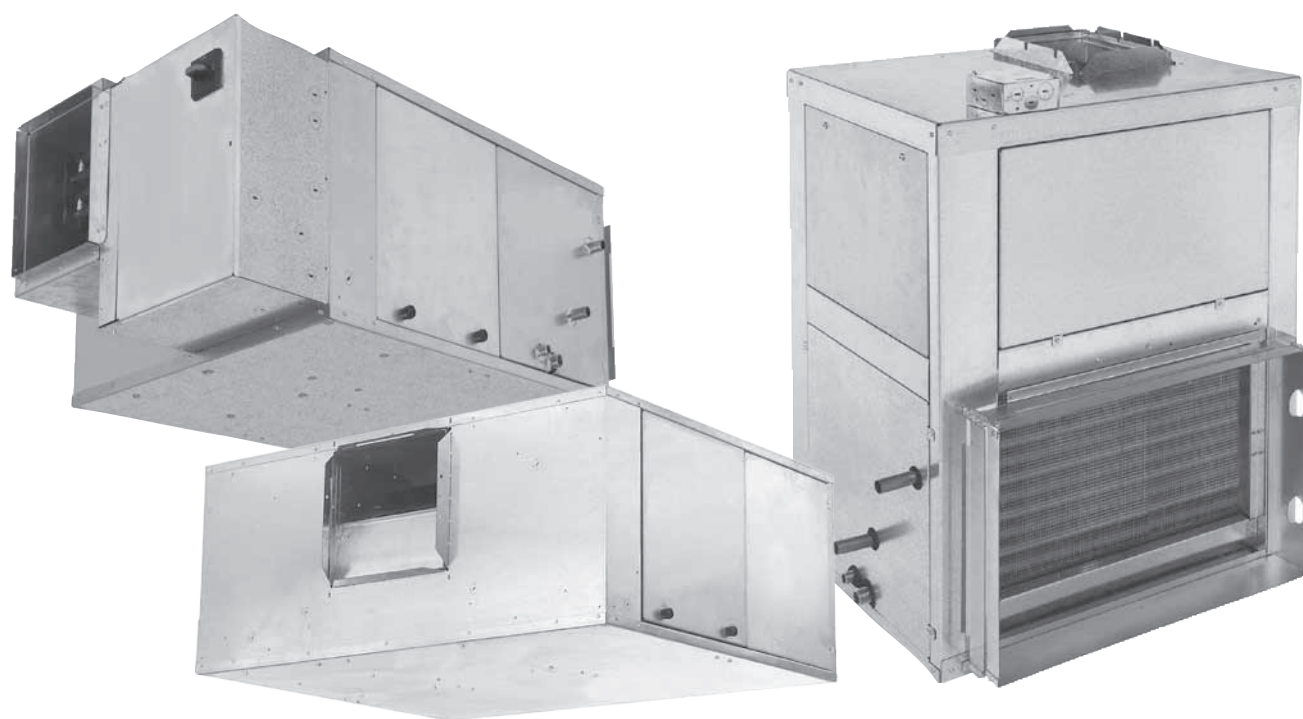

Belt Drive Models:

HBD, VBA

BUILD YOUR REPUTATION ON OURS

Belt Drive Series Fan Coils

INSTALLATION, OPERATION, & MAINTENANCE MANUAL

- 3 Preface
- 3 Unpacking and Inspection
- 3 Installation – Mounting
- 5 Mixing Box Installation
- 7 Ductwork
- 7 Drain Connection
- 7 Piping
- 7 Electrical Connections
- 7 Startup
- 8 Equipment Installation and Start-Up Check List
- 9 Terms and Conditions

International Environmental Corporation (IEC) works continually to improve its products. As a result, the design and specifications of each product may be changed without notice and may not be as described herein. Please contact IEC for information regarding current design and product specifications. Statements and other information contained herein are not express warranties and do not form the basis of any bargain between the parties but are merely IEC's opinion or commendation of its products. Manufacturer's standard limited warranty applies.

Preface

IEC employs rigid quality standards in its product designs and manufacturing processes to create high quality products you can rely on. However, in the rare instance when a problem is encountered, the equipment is initially protected under the manufacturer's standard warranty. This warranty is provided under the condition that the steps outlined in this guide for initial inspection, installation, and operation of the equipment, are followed in detail. This guide MUST be fully reviewed in advance of any actual work being done on the equipment.

This guide only covers general topics. Consult the approved unit submittals, order acknowledgement, and other manuals for details on the options and accessories provided with the equipment.

All installations MUST be made in compliance with all governing codes. Compliance with all codes is the responsibility of the installing contractor.

All installation and service should be performed only by qualified, trained personnel.



CAUTION: Disconnect all power supplies before attempting installation or service.

More than one power supply may need to be disconnected on some equipment.



CAUTION: Electric shock can cause death.



CAUTION: Observe all warnings and precautions marked on the equipment.

Never wear bulky or loose fitting clothing while working on mechanical equipment. Gloves and safety glasses should be worn at all times.

Unpacking and Inspection

Thoroughly inspect all units for damage upon arrival. If exterior is undamaged, unit may be opened. Inspect all contents for visible and hidden damage. If damage is found, immediately file a claim with the freight carrier.

Installation – Mounting

Sufficient clearance must be maintained for service and maintenance. Minimum recommended clearance for maintenance of motor, pulley, and belt is 24" on the access

side of the unit. Filters can be removed from the side or the top of the vertical blower coil units and from the side and the bottom of the horizontal blower coil units. If side access to the filter is desired, the minimum clearance required is the width of the filter rack plus 6".

A minimum of 48" clearance is required between factory supplied electric heater and a field supplied combustible component placed downstream of the unit.

The unit must be mounted level. DO NOT mount the unit on a slope. The drain pan has a built-in slope to ensure proper drainage. Mounting the unit on a slope may result in improper drainage. Field-furnished and installed accessories such as ductwork, mixing boxes, economizers, dampers, etc. must be independently supported or suspended and must not rely on the unit for support.

Vertical Units (Standard)

Vertical blower coils can be installed with or without mixing boxes. For units with mixing boxes, a base rail must be used. Follow the mixing box installation instructions outlined in the next section.

Vertical units need to be installed on a pad or on a base rail. The height of the pad should be adequate to allow proper trapping for condensate drain.

Figure 1 illustrates how to calculate a minimum height of a pad to allow a proper p-trap clearance. The example is for a unit with a total static pressure (TSP) of 2" w.c. and a 1" w.c. safety factor for any change in operating conditions. The minimum height, "C," is the height from bottom of unit to finished floor.

Minimum Height Clearance:

$$\begin{aligned} &= (\text{TSP} + \text{Safety Factor}) \times 1.5 + \text{Tube Diameter} \\ &= (2" + 1") \times 1.5 + 3/4" = 5-1/4" \end{aligned}$$

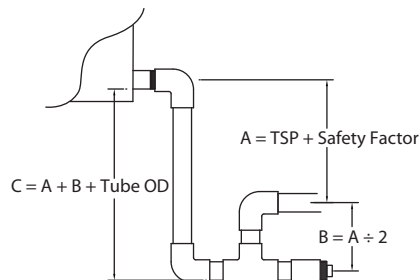

Figure 1. P-Trap Clearance

Belt Drive Series Fan Coils

INSTALLATION, OPERATION, & MAINTENANCE MANUAL

Vertical Units with Seismic Structural Upgrade Option

The units with seismic structural upgrade option need to be secured to a pad or a base rail using factory-installed mounting brackets. Anchor hardware is to be furnished by others and must be Hilti Kwik bolt TZ Expansion Anchors or similar carbon steel anchor tested in accordance with ACI 355.2 and ICC-ES AC 193. Anchor size is specified in Figure 2. The mounting hole locations and added dimensional data is shown in Table 1 and Figure 2.

UNIT SIZE VBA	DIMENSIONS (IN)					
	A	B	C	D	E	F (REF)
06-08	29.59	N/A	N/A	16.00	2.00	N/A
10-12	38.56	N/A	N/A	18.00	2.00	N/A
16	15.06	14.00	2.00	18.00	2.00	48.56
20	15.16	14.50	2.00	20.00	2.00	49.56
30	16.06	14.00	2.00	24.00	2.00	49.56
40	21.06	18.50	2.00	22.00	3.00	63.56

Table 1. Mounting Hole Locations

VBA40 SEISMIC INSTALLATION

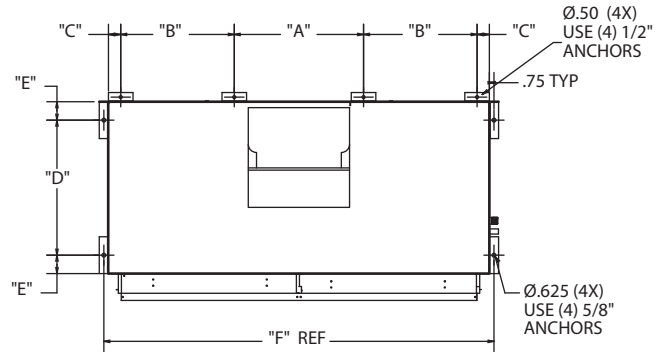

Figure 2. Mounting Details–Seismic Structural Upgrade Option

Horizontal Units (Standard)

Install the mixing box if the unit is ordered with one. Follow the mixing box installation instructions outlined in the next section.

The horizontal blower coil units have 5/8" knockouts in each corner of the top and bottom panels for suspension rods to pass through (see Figure 3). Be sure to support the unit from underneath until mounting is complete.

VBA06-12 SEISMIC INSTALLATION

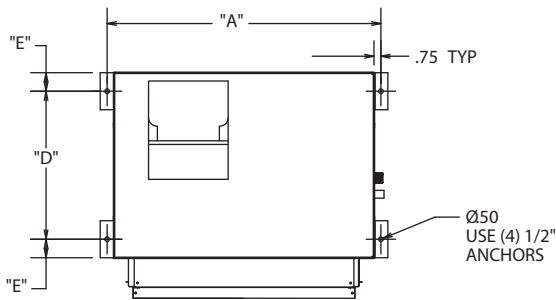

VBA16-30 SEISMIC INSTALLATION

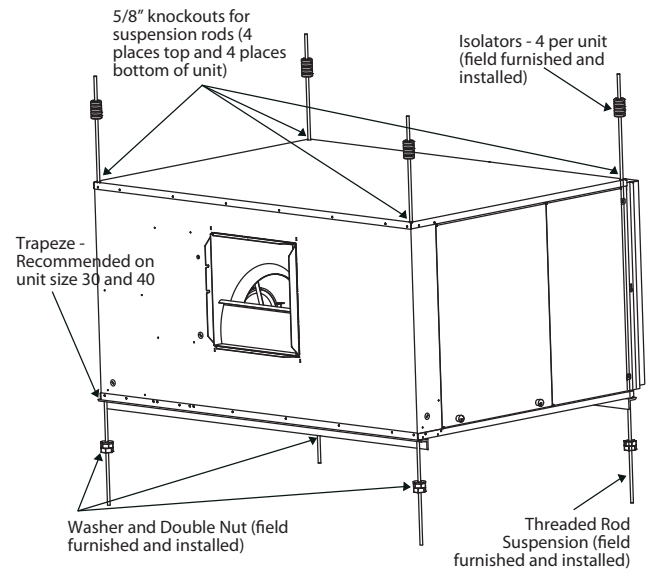
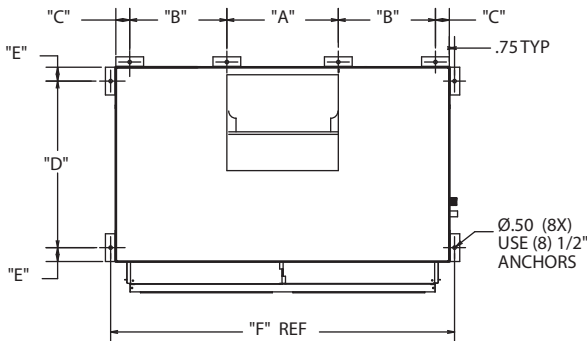

Figure 3. Threaded Rod Suspension

Belt Drive Series Fan Coils

INSTALLATION, OPERATION, & MAINTENANCE MANUAL

It is recommended that a trapeze suspension be used on sizes 30 and 40 as shown in Figure 3 and 4. Size your trapeze to ensure you do not block bottom access for filter removal.

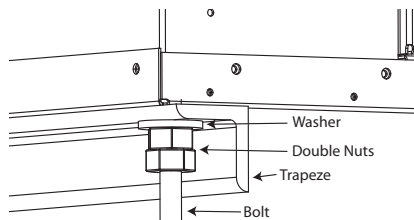
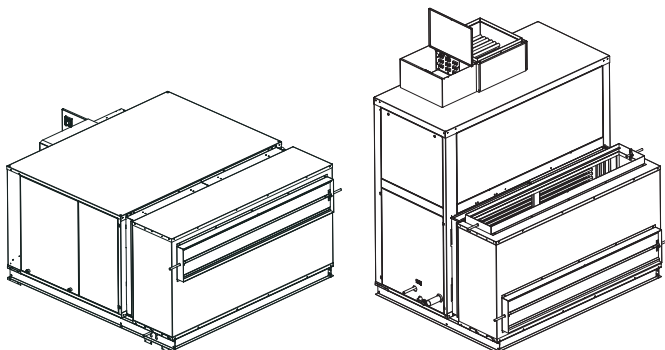

Figure 4. Mounting Details—Threaded Rod Suspension

Horizontal Units with Seismic Structural Upgrade Options

For the units with seismic structural upgrade option, follow the same instruction as the standard.

Mixing Box Installation



1. Mixing boxes are preassembled from the factory for ease of installation. A linkage kit consisting of two crank arms, 2 swivels, and either a 25" (sizes 06-16) or a 34" (sizes 20-40) length of 5/16" rod is provided for field installation of an actuator.

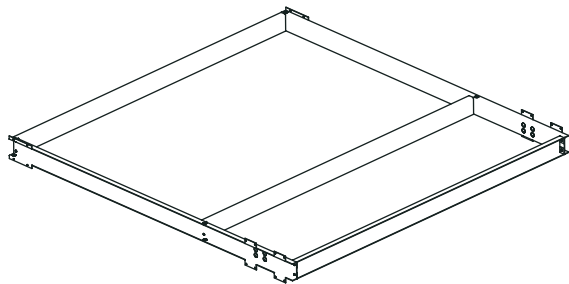

Figure 5. Base Rails

2. Assemble the base rails (provided with mixing box). All hardware required for assembly is included and the base rails are letter coded for ease of assembly (as shown in Figure 6).

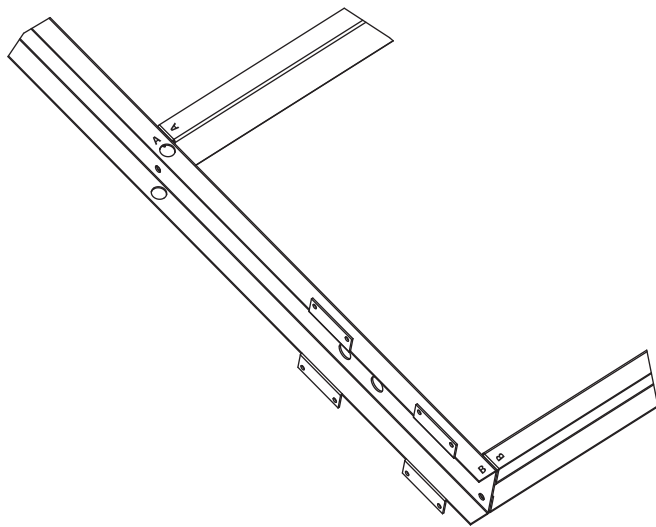

Figure 6. Letter Coding on Base Rail Parts

3. Place unit on the base rails. Then install mixing box and attach to base rail using the #8 x 1/2" fasteners at the locations shown in Figure 7 and 8.
4. Seal the connection between the mixing box and the return duct flange. Be careful not to tape or seal the filter access panel.

Belt Drive Series Fan Coils

INSTALLATION, OPERATION, & MAINTENANCE MANUAL

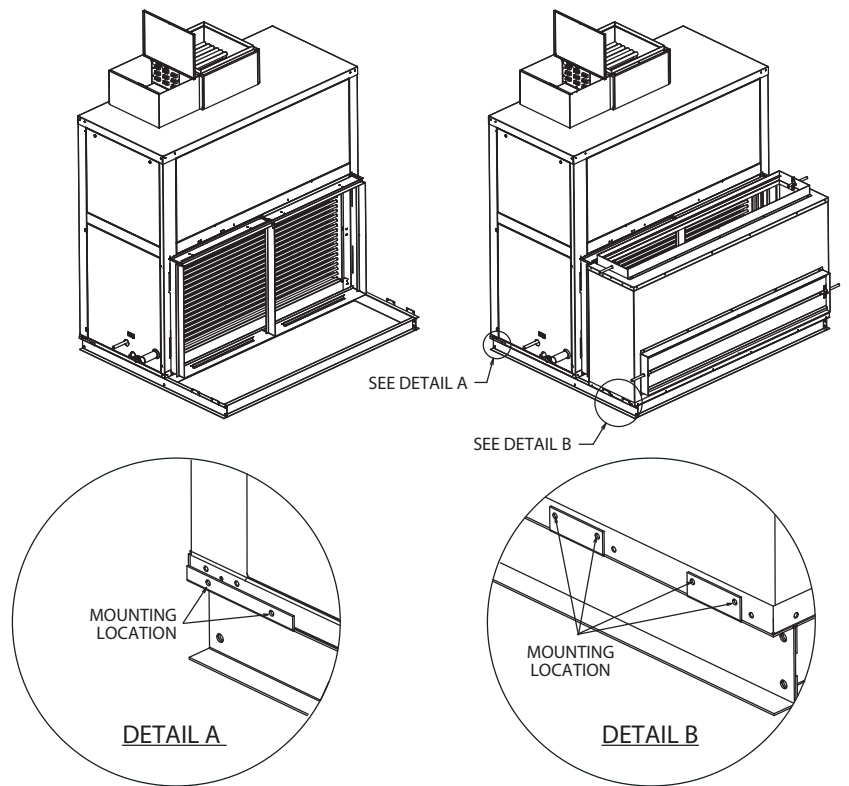

Figure 7. Vertical Units with Mixing Box Option

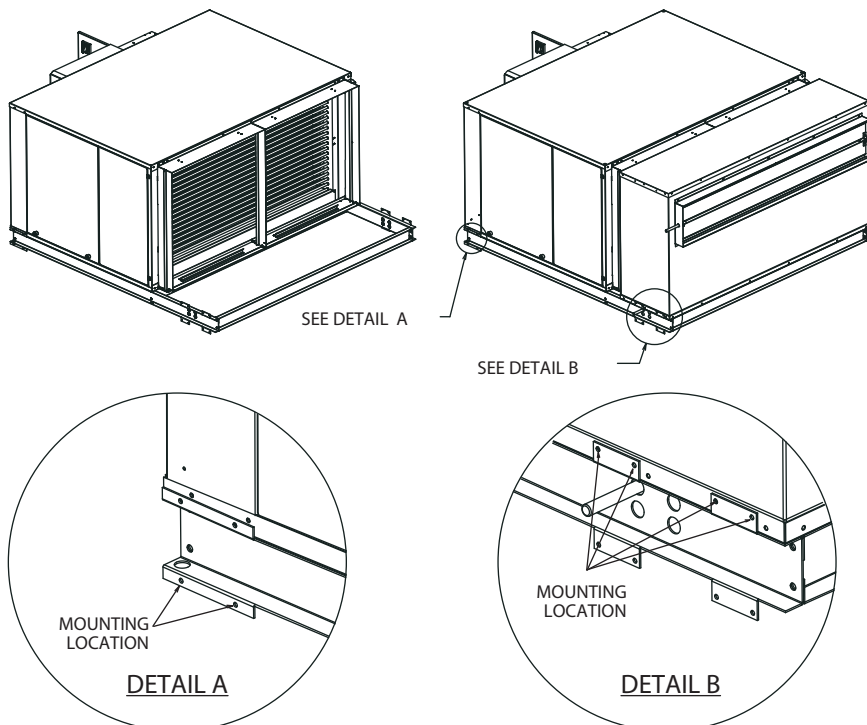

Figure 8. Horizontal Units with Mixing Box Option

Ductwork

All ductwork and/or supply and return grilles should be installed in accordance with the project plans and specifications. Follow local code requirements, ASHRAE, SMACNA rules and guidelines for design and installation of ductwork. If ducted, use flexible duct connectors on supply and return sides. Acoustic lining of main supply and return duct should be considered for noise control. Do not attach suspension wires to unit or through ducts. Noise transmission will be reduced with return air grilles located as far as possible from the unit.

The manufacturer assumes no responsibility for undesirable system operation due to improper design, equipment or component selection, and/or installation of ductwork, grilles, and other related components.

Drain Connection

Condensate drain pan has a built-in bi-directional slope to ensure complete drainage. Condensate drain must be a minimum of 3/4" of copper, galvanized, black iron, or PVC piping. Condensate drain **MUST** be trapped for proper drainage. If drain is not properly trapped, drain pan may overflow.

Drain line must pitch downward 1" for every 10' of length. Drain pan has a secondary connection intended for use if main connection is not working as designed. This secondary connection must be piped to an open-site drain in the event that the primary drain becomes blocked. If the unit is located where overflow caused by blockage of the primary drain will not cause any damage to building structure or components, the secondary drain may be capped. All drain piping must comply with local code requirements.

Piping

The supply and return connections are marked on the coil stub-outs with "S" for supply (inlet) and "R" for return (outlet). Blue letters mark the chilled water connections and red letters mark the hot water or steam connections. All factory assembled valve packages will be identified with a corresponding tag for ease of installation. After the connections are completed, the system should be tested for leaks. Hydronic systems should be tested with water, as some components are not designed to hold pressure with a gas. If a gas must be used for testing, under no circumstances should the gas pressure exceed 80 psi. **All chilled water piping and valves not located over drain pans or drip lips must be insulated to prevent damage from sweating.**

Electrical Connections

The unit nameplate shows the supply voltage, motor and heater amperage, and required minimum circuit ampacity. The wiring diagram provided with the unit shows all factory and field wiring. Most of the motors used on the HBD or VBA are dual voltage motors. These motors are factory wired for the specified voltage. The motor should be checked for correct voltage and rotation at the time of installation.

Units ordered with factory installed motor controls and disconnect meet NEC requirements for disconnect, motor controller, and motor overload protection. A separate disconnect and motor starter is not necessary to meet NEC requirements.

All field wiring should be done in accordance with governing codes and ordinances. **Any modification of the unit wiring without factory authorization will result in voiding all factory warranties and will nullify any agency listings.**

The manufacturer assumes no responsibility for any damages and/or injuries resulting from improperly installed or wired components.

Startup

Startup personnel should be familiar with the unit, options and accessories, and control sequence. All personnel should have a good working knowledge of general startup procedures. All equipment should be inspected to verify that all systems are complete and properly installed and mounted, and that no debris or foreign articles are left in the units. Each unit should be checked for loose wires, free blower wheel operation, and loose or missing access panels. The belt drives are factory set at the speed required for the design conditions specified at the time of order. These drives may be adjusted to achieve a different speed by qualified personnel during air system balancing. When adjusting the belt drive system, care must be taken to maintain proper drive belt alignment and tension. The drive belt should be tensioned to allow deflection of no more than 3/16" under an 8 lb. force at midpoint between the pulleys. The unit should not be operated without all proper ductwork attached, and all access panels in place and secure.



CAUTION: A clean set of filters must be installed after commissioning.



CAUTION: All panels must be in place when the motor is running.

Belt Drive Series Fan Coils

INSTALLATION, OPERATION, & MAINTENANCE MANUAL

Equipment Installation and Start-Up Check List

IEC blower coils represent a prudent investment which can give trouble-free operation and long service. The reliable operation and long service life of this equipment can be improved with proper installation and operation and regular maintenance. The equipment is initially protected under IEC's standard warranty. This warranty is provided under the condition that the following steps be followed in detail. Should any questions arise, please contact your local sales representative or the factory before attempting any installation or operation of the equipment.

Receiving and Inspection

- Unit received undamaged
- Unit received complete as ordered
- "Furnish only" parts accounted for
- Unit arrangement/hand correct
- Unit structural support complete and correct

Handling and Installation

- Unit is secure and mounted properly
- Mounting grommets/isolators used
- Unit mounted level and square
- Proper access provided for unit and accessories
- Proper electrical service provided
- Proper overcurrent protection provided
- Proper service switch/disconnect provided
- Proper chilled water line size for unit
- Proper hot water line size for unit
- All services to unit in code compliance
- All shipping screws and braces removed
- Unit protected from dirt and foreign matter

Cooling/Heating Connections

- Connect field piping to unit
- Pressure test all piping for leaks
- Flush water systems
- Install drain line and traps, as required
- Insulate all piping and valves, as required

Ductwork Connections

- Install ductwork, fittings and grilles, as required
- Flexible duct connections at unit
- Proper supply and return grille type and size used
- Insulate all ductwork, as required

Electrical Conditions

- Refer to unit wiring diagram
- Connect incoming power service or services
- Install and connect "furnish only" parts

Unit Start-up

- General visual unit and system inspection
- Check that unit is level
- Record electrical supply voltage

- Check all wiring for secure connections
- Verify with straight edge alignment of motor and blower pulleys
- Tighten all set screws
- Confirm V-belt is properly tightened
- Check condensate drain connection
- Verify trap is deep enough
- Prime the trap with water.
- Check supply and return water connections for leaks
- Fill systems with water by opening supply ball valve and control valve
- Open air vent on top of coil to vent air out of system
- Open return ball valve
- Engage power only long enough to verify proper blower rotation
- Check all ductwork and grilles in place
- Check all unit panels and filters in place
- Start fans, pumps, chillers, etc.
- Check for overload conditions of all units
- Check all ductwork and units for air leaks
- Balance water systems, as required
- Balance air systems, as required
- Record all final settings for future use
- Check piping and ductwork for noise or vibration
- Check all dampers for proper operation
- Verify proper cooling operation
- Verify proper heating operation
- Reinstall all covers and access panels
- Verify proper condensate drainage

Recommended Maintenance

Quarterly

- Lubricate motor and blower bearings (if applicable)
- Check and adjust belt tension
- Change air filters

Annually—in addition to quarterly maintenance

- Inspect all wiring connections and tighten if necessary
- Check and tighten set screws on pulleys
- Clean coil and drain pan
- Clean Blower wheel as needed

TERMS AND CONDITIONS

- Orders shall not be binding upon International Environmental Corporation, an Oklahoma corporation (hereinafter referred to as "IEC") unless accepted by an authorized representative of IEC at its office in Oklahoma City, Oklahoma. No distributor, sales representative or any other person or entity (except authorized employees of IEC at its office in Oklahoma City, Oklahoma) has any authority whatsoever to bind IEC to any representation or agreement of any kind.
- IEC does not build items to plans and specifications. IEC agrees to furnish only the items as described in IEC's acknowledgment unless IEC's office in Oklahoma City, Oklahoma has previously received and accepted, in writing, approved submittals from Purchaser.
- Prices acknowledged are firm only if Purchaser releases the goods covered by this order for immediate production by IEC within sixty (60) days from the date of Purchaser's initial offer to purchase and for shipment by IEC within IEC's estimated shipping date, unless otherwise agreed to in writing by IEC at its office in Oklahoma City, Oklahoma. If Purchaser does not meet the terms and conditions of this paragraph, the prices are subject to escalation to those prices in effect at time of shipment without notice to Purchaser.
- All prices are F.O.B. IEC's factory, unless otherwise agreed by IEC in writing; and, all payments and prices shall be in U.S.A. dollars.
- If goods are released for production but IEC is prevented by the Purchaser from shipping upon completion or by IEC's estimated shipping date, whichever is later, IEC may at its option, in addition to all other remedies, invoice Purchaser to be payable within thirty (30) days and store the goods at Purchaser's sole expense.
- Title to and risk of loss to the goods passes to the Purchaser F.O.B. IEC's factory.
- Disclaimer**

It is expressly understood that unless a statement is specifically identified as a warranty, statements made by IEC or its representatives relating to IEC's products, whether oral, written or contained in any sales literature, catalog or any other agreement, are not express warranties and do not form a part of the basis of the bargain, but are merely IEC's opinion or commendation of IEC's products. **EXCEPT AS SPECIFICALLY SET FORTH HEREIN, THERE IS NO EXPRESS WARRANTY AS TO ANY OF IEC'S PRODUCTS. IEC MAKES NO WARRANTY AGAINST LATENT DEFECTS. IEC MAKES NO WARRANTY OF MERCHANTABILITY OF THE GOODS OR OF THE FITNESS OF THE GOODS FOR ANY PARTICULAR PURPOSE.**
- Grant of Limited Express Warranty**

IEC warrants IEC products purchased and retained in the United States of America and Canada to be free from defects in material and workmanship under normal use and maintenance as follows: (1) All complete fan coil units built or sold by IEC for twelve (12) months from date of unit start up or eighteen (18) months from date of shipment (from factory), whichever comes first.

All parts must be returned to IEC's factory in Oklahoma City, Oklahoma, freight prepaid, no later than sixty (60) days after the date of the failure of the part; if IEC determines the part to be defective and within IEC's Limited Express Warranty, IEC shall, when such part has been either replaced or repaired, return such to a factory recognized contractor or service organization, F.O.B. IEC's factory, Oklahoma City, Oklahoma, freight prepaid. The warranty on any parts repaired or replaced under warranty expires at the end of the original warranty period. For information and warranty service contact:

International Environmental Corporation
Customer Service
5000 West I-40
Oklahoma City, OK 73128
(405) 605-5000

This warranty does not cover and does not apply to: (1) Air filters, fuses, fluids; (2) Products relocated after initial installation; (3) Any portion or component of any system that is not supplied by IEC, regardless of the cause of the failure of such portion or component; (4) Products on which the unit identification tags or labels have been removed or defaced; (5) Products on which payment to IEC is or has been in default; (6) Products which have defects or damage which result from improper installation, wiring, electrical imbalance characteristics or maintenance; or are caused by accident, misuse or abuse, fire, flood, alteration or misapplication of the product; (7) Products which have defects or damage which result from a contaminated or corrosive air or liquid supply or operation at abnormal temperatures; (8) Mold, fungus or bacteria damages; (9) Products subjected to corrosion or abrasion; (10) Products manufactured or supplied by others; (11) Products which have been subjected to misuse, negligence or accidents; (12) Products which have been operated in a manner contrary to IEC's printed instructions; or (13) Products which have defects, damage or insufficient performance as a result of insufficient or incorrect system design or the improper application of IEC's products.

IEC is not responsible for: (1) The cost of any fluids or other system components, or associated labor to repair or replace the same, which is incurred as a result of a defective part covered by IEC's Limited Express Warranty; (2) The costs of labor, materials or service incurred in removal of the defective part, or in obtaining and replacing the new or repaired part; or, (3) Transportation costs of the defective part from the installation site to IEC or of the return of any part not covered by IEC's Limited Express Warranty.

Limitation: This Limited Express Warranty is given in lieu of all other warranties. If, notwithstanding the disclaimers contained herein, it is determined that other warranties exist, any such warranties, including without limitation any express warranties or any implied warranties of fitness for particular purpose and merchantability, shall be limited to the duration of the Limited Express Warranty.
- Limitation of Remedies**

In the event of a breach of the Limited Express Warranty, IEC will only be obligated at IEC's option to repair the failed part or unit or to furnish a new or rebuilt part or unit in exchange for the part or unit which has failed. If after written notice to IEC's factory in Oklahoma City, Oklahoma of each defect, malfunction or other failure and a reasonable number of attempts by IEC to correct the defect, malfunction or other failure and the remedy fails of its essential purpose, IEC shall refund the purchase price paid to IEC in exchange for the return of the sold good(s). Said refund shall be the maximum liability of IEC. THIS REMEDY IS THE SOLE AND EXCLUSIVE REMEDY OF THE BUYER OR THEIR PURCHASER AGAINST IEC FOR BREACH OF CONTRACT, FOR BREACH OF ANY WARRANTY OR FOR IEC'S NEGLIGENCE OR IN STRICT LIABILITY.
- Limitation of Liability**

IEC shall have no liability for any damages if IEC's performance is delayed for any reason or is prevented to any extent by any event such as, but not limited to: any war, civil unrest, government restrictions or restraints, strikes, or work stoppages, fire, flood, accident, shortages of transportation, fuel, material or labor, acts of God or any other reason beyond the sole control of IEC. **IEC EXPRESSLY DISCLAIMS AND EXCLUDES ANY LIABILITY FOR CONSEQUENTIAL OR INCIDENTAL DAMAGE IN CONTRACT, FOR BREACH OF ANY EXPRESS OR IMPLIED WARRANTY, OR IN TORT, WHETHER FOR IEC'S NEGLIGENCE OR AS STRICT LIABILITY.**
- IEC shall have no system design, application or maintenance responsibility or responsibility for mold, fungus or bacteria to Purchaser or any other third party.
- All sales, goods and services, use, excise, value added, transportation, privilege, occupational consumption, storage, document, transaction or other taxes which may be levied by any taxing authority as a result of this transaction shall be paid by the Purchaser.
- Unless otherwise agreed to in writing by IEC any technical data furnished in conjunction with this order and not obtainable from another source shall not be duplicated, used, or disclosed in whole or in part for any purpose other than to evaluate this order.
- IEC shall have no liability or other obligation hereunder, if IEC's performance is delayed for any reason or is prevented to any extent by any event such as, but not limited to: any act of God, strike or work stoppage, fire, flood, accident, allocation, or other controls of Government authorities, shortages of transportation, fuel, material or labor, or any other cause beyond IEC's sole control. Any shipping date stated by IEC is IEC's best estimate but IEC makes no guarantee of shipment by any such date and shall have no liability or other obligation for failure to ship on such date, regardless of cause.
- Payment terms are net thirty (30) days from date of shipment on approved credit. One and one half percent (1 1/2%) per month (18% annual rate) may be charged on past due accounts or the highest rate permitted by applicable law, whichever is lesser. In the event the account is placed for collection, Purchaser shall be responsible for all reasonable attorneys fees or costs on a solicitor and client basis, plus all other costs and expenses incurred by IEC in securing payment.
- Purchaser shall not cancel the contract without prior written consent of an authorized representative of IEC at its offices in Oklahoma City, Oklahoma. In the event Purchaser cancels the contract with the prior written consent of IEC after the Purchaser's offer to purchase is received and acknowledged in writing, IEC shall be entitled to receive from Purchaser IEC's cost incurred to time of cancellation plus a reasonable allowance for overhead and profit.
- Purchaser shall not assign any of its interest or rights under this agreement without written consent of IEC.
- IEC will protect all its lien rights. IEC will not furnish lien waivers or releases until IEC receives payment, in full, at its office in Oklahoma City, Oklahoma from Purchaser for the goods covered by this order. There is no authorized retainage for any reason.
- This Agreement shall be construed, and the rights and liabilities of the parties hereunder shall be determined in accordance with the laws of the State of Oklahoma. If it shall be found that any portion of this agreement violates any particular law of the United States or any state in the United States having jurisdiction or, if applicable, any law of Canada or any province or territory in Canada having jurisdiction, such portion of the agreement shall be of no force and effect in that political unit, division or sub-division in which they are illegal or unenforceable and the agreement shall be treated as if such portion or portions had not been inserted. In the event that any dispute or disagreement in connection with any order should arise or exist between Purchaser and IEC, jurisdiction and venue for any legal action shall be, if IEC so elects, exclusively in the state or federal courts in Oklahoma County, Oklahoma. The statute of limitations on any claim of the Purchaser against the IEC shall be one (1) year from the date the cause of action accrues.
- Without regard to any other agreement, all obligations of Purchaser to IEC shall become immediately due and payable if Purchaser becomes insolvent or if Purchaser does not make payments when due or breaches any other agreement or fails to perform any obligation.
- All orders are expressly limited and made conditional upon acceptance by Purchaser of the terms and conditions set forth above without change. There shall be no understandings, agreements, or obligations (outside these terms and conditions) unless specifically set forth in writing and accepted by signature of an authorized representative of IEC in Oklahoma City, Oklahoma.
- The parties hereto have requested that these presents and all judicial proceedings relating thereto be drafted in English. Les parties aux présentes ont demandé à ce que les présentes et toutes procédures judiciaires y afférentes soient rédigées en anglais.

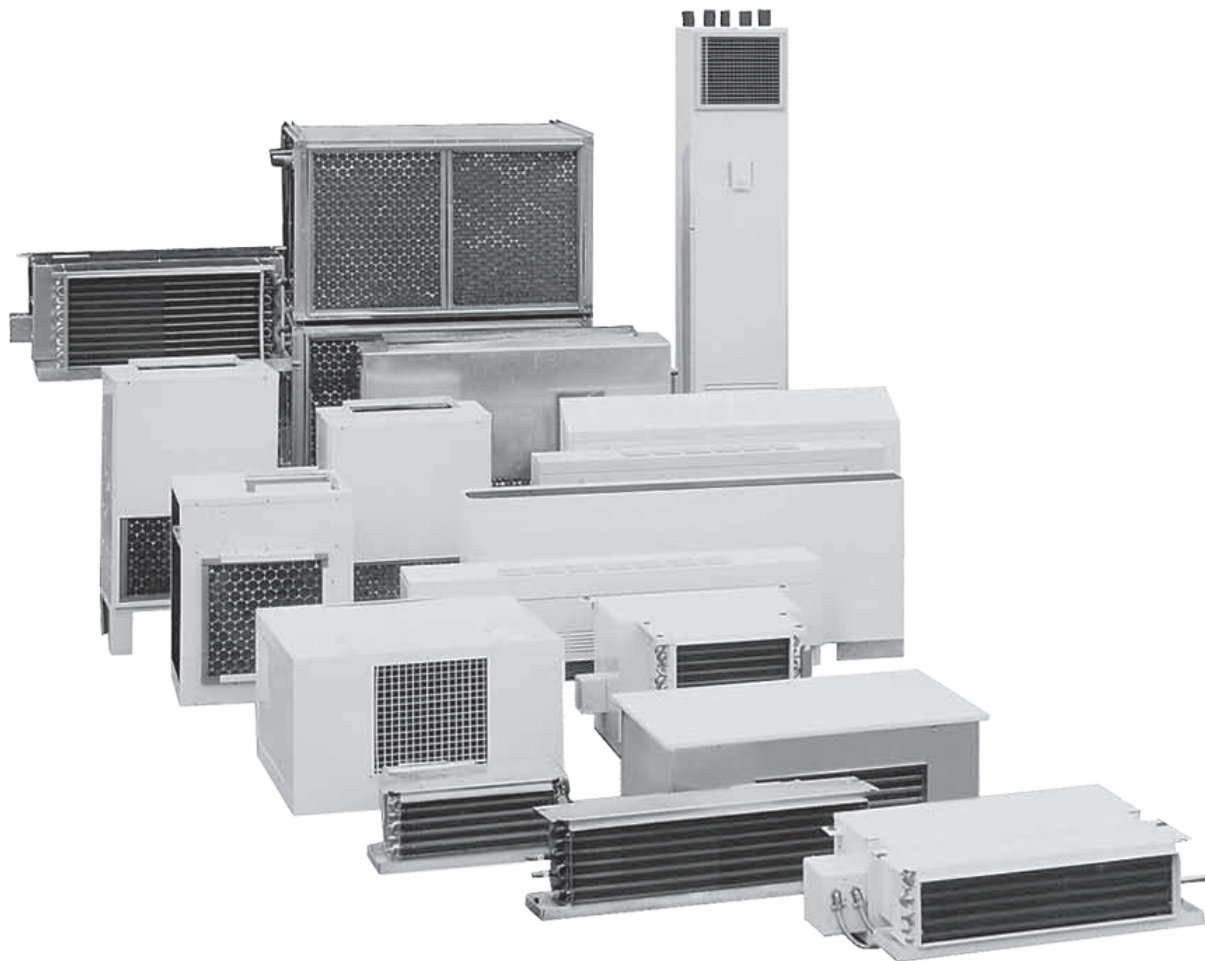

Belt Drive IOM Part #: I100-90002124

IOM-060 Revision 8

©2011 International Environmental Corporation (IEC)

IEC is a subsidiary of LSB Industries, Inc.

NYSE symbol LXU; www.lsb-okc.com

P.O. Box 2598
Oklahoma City, OK 73101-2598
p: 405.605.5000
f: 405.605.5001
www.iec-okc.com