

**INSTALLATION
INSTRUCTIONS**

**P/N E055-71520301
P/N E055-71520304**

**FAN COIL
NON-PROGRAMMABLE
DIGITAL THERMOSTAT**

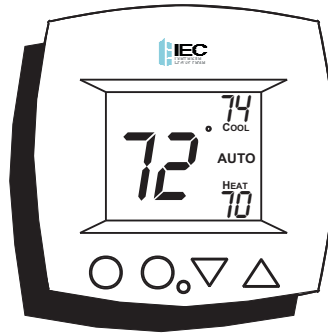

2- OR 4-PIPE • NON-PROGRAMMABLE

- *Auto-Changeover is available in 4-pipe systems, in 2-pipe systems with Electric Heat, or when used with G100-71520306 accessory, auto-changeover sensor.*



© Copyright 2007, International
Environmental Corp. All Rights Reserved

Table Of Contents

Step #1: Preparation	2
Step #2: Remove & Replace Old Thermostat	3
Step #3: Wire Connections	4
Sample Wiring Diagrams	6
Step #4: Test Operation	11
Trouble Shooting	16
Warranty	18

CAUTION



Follow Installation Instructions carefully. Disconnect Power to the Heater/Air Conditioner before removing the old thermostat and installing the new thermostat.



WARNING

P/N E055-71520301 and P/N E055-71520304

© Copyright 2007, International
Environmental Corp. All Rights Reserved

STEP #1

PREPARATION



Proper installation of the thermostat will be accomplished by following these step by step instructions. If you are unsure about any of these steps, call a qualified technician for assistance.



Assemble tools.



*Flat Blade
Screwdriver*

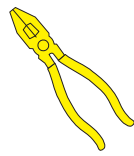

*Wire cutter
& Stripper*



*Drill with 3/16
inch Drill Bit
(when not
using j-box)*



Make sure your Heater/Air Conditioner is working properly before beginning installation of the thermostat.



Carefully unpack the thermostat. Save the screws, wall anchors, and instructions.



Turn off the power to the Heating/Air Conditioning system at the main fuse panel.

STEP #2 REMOVE & REPLACE OLD THERMOSTAT
(IF APPLICABLE)



Remove the cover of the old thermostat. If it does not come off easily check for screws.



Loosen the screws holding the thermostat base or subbase to the wall and lift away.



Disconnect the wires from the old thermostat. Tape the ends of the wires as you disconnect them and mark them with the letter of the terminal for easy reconnection to the new thermostat.



Keep the old thermostat for reference purposes until your new thermostat is functioning properly.

Note: This thermostat is strictly a low voltage control. One or two E025-71520303 relay boards **must** be installed to isolate the 24 volt wires from the line voltages to the fan, and possibly the water valves.

STEP #3**WIRE CONNECTIONS**

If the terminal designations on your old thermostat do not match those on the new thermostat, ***refer to the chart below, or the wiring diagrams that follow.***

4-PIPE SYSTEMS

Wire from the old thermostat terminal marked	Function	Install on the new thermostat terminal marked
Y1, Y or C	Cooling	Y1
W1, W or H	Heating	W1
Rh, R, M, Vr, A	Power	R
C	Common	C
G, F or LOW	Low Fan Speed	G
MED	Medium Fan Speed	G2
HIGH	High Fan Speed	G3

Note: Be sure to seal any opening through the wall behind the thermostat to prevent improper temperature sensing of the conditioned space.

STEP #3**WIRE CONNECTIONS**

If the terminal designations on your old thermostat do not match those on the new thermostat, ***refer to the chart below, or the wiring diagrams that follow.***

2-PIPE SYSTEMS

Wire from the old thermostat terminal marked	Function	Install on the new thermostat terminal marked
Y1, Y or C	Water Valve	Y1
W1, W or H	Strip Heater	W1
Rh, R, M, Vr, A	Power	R
C	Common	C
G, F or LOW	Low Fan Speed	G
MED	Medium Fan Speed	G2
HIGH	High Fan Speed	G3

Note: Be sure to seal any opening through the wall behind the thermostat to prevent improper temperature sensing of the conditioned space.

Sample Wiring Diagram

4-Pipe, 2 Relay Boards, Line Voltage Water Valves

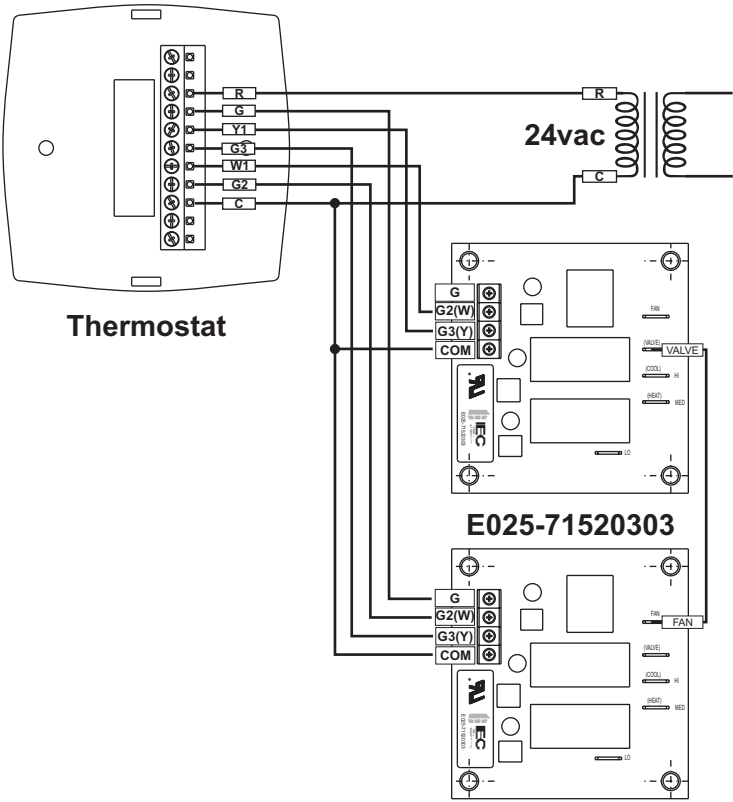

Sample Wiring Diagram

4-Pipe, Low Voltage Valves, Duct Temperature Sensor & Dry Contact

Duct Sensor
G100-71520307

Important Note: If a Duct sensor is connected to this thermostat it is suggested that the fan be programmed for continuous operation (step #5, page 11 of the Owner's Manual).

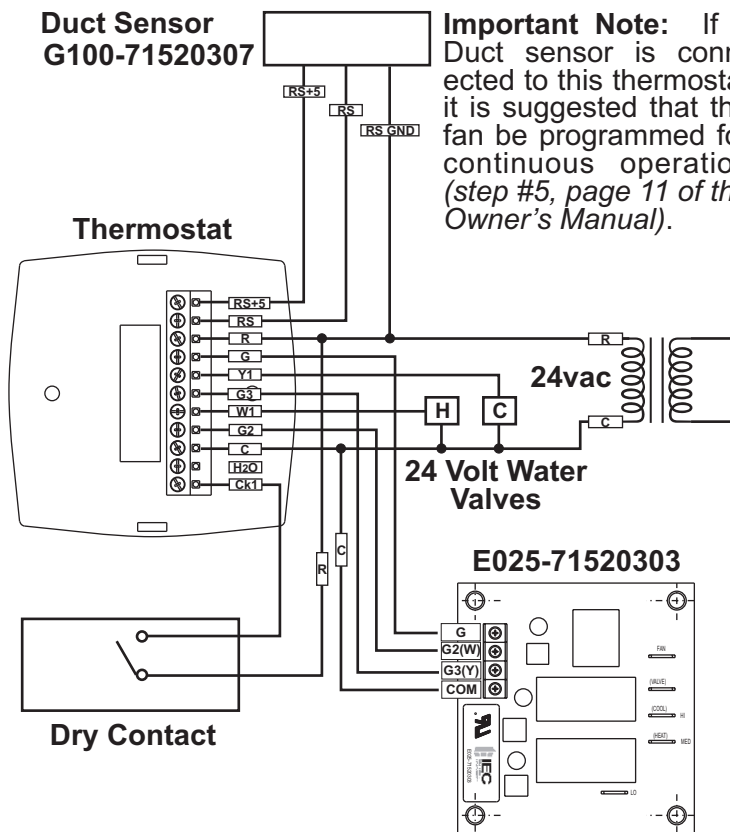

Sample Wiring Diagram

2-Pipe, Low Voltage Valve, Heat Only or Cool Only

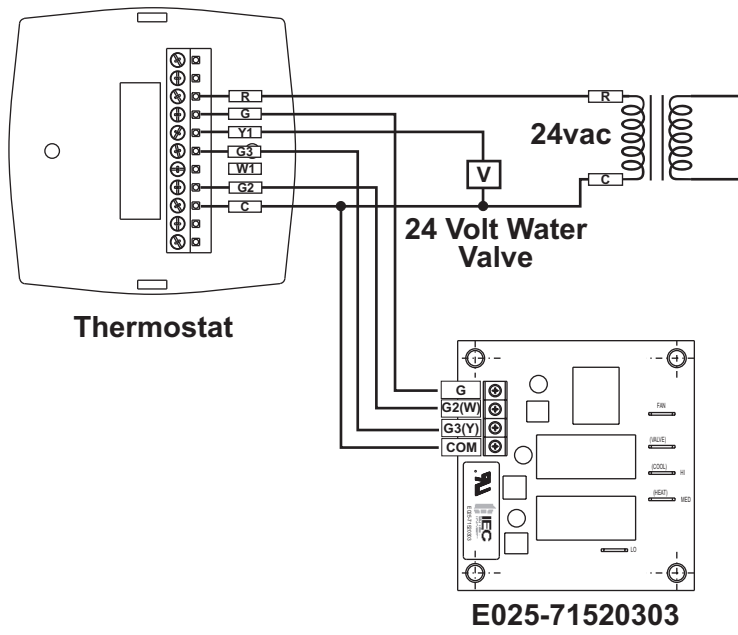

Sample Wiring Diagram

2-Pipe, Low Voltage Valve, H2O Changeover Sensor

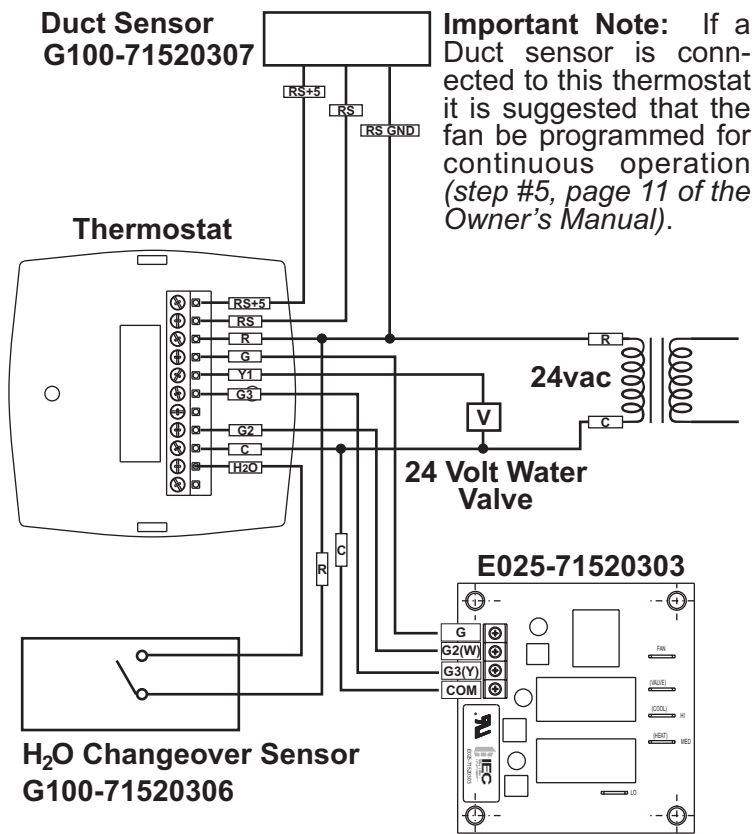

Sample Wiring Diagram

2-Pipe, Low Voltage Valve, Chilled Water with Electric Strip Heat

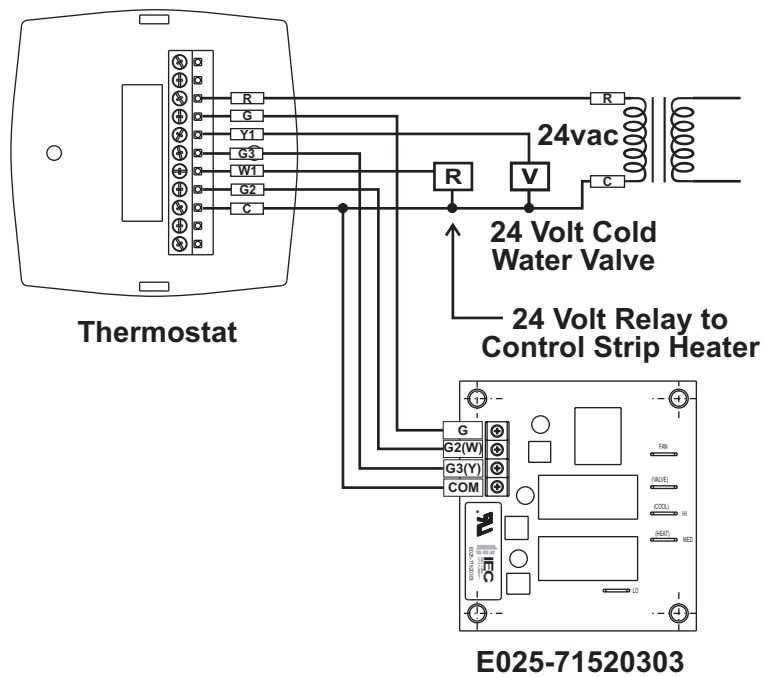

STEP #4**TEST OPERATION****4-PIPE SYSTEM**

Turn the power on to the Fan Coil Unit.



Press the MODE button repeatedly until the **HEAT** icon appears on the display. Press the UP or DOWN buttons until the set temperature is 10 degrees above room temperature. The hot water valve will open and the fan will be running.



Press the MODE button repeatedly until the **COOL** icon appears on the display. Press the UP or DOWN buttons until the set temperature is 10 degrees below room temperature. The cold water valve will open and the fan will be running.



Press the UP button until the setpoint is equal to the room temperature. Press the Fan button repeatedly until a single bar appears next to the Fan icon. Confirm the fan is running on low speed. Press the Fan button again, confirm the fan is running on medium speed. Again, press the Fan button, confirm the fan is running at high speed. Press the Fan button once more, the bars next to the Fan icon should disappear.



Press the MODE button repeatedly until the **OFF** icon appears on the display. Both valves will be closed and the fan will be off.

STEP #4

TEST OPERATION

2-PIPE, CHANGEOVER SENSOR, NO STRIP HEAT



Turn the power on to the Fan Coil Unit and confirm that the thermostat is programmed correctly in setup steps #3 and #4 on page 11 of the Owner's Manual.



If hot water is available, press the MODE button repeatedly until the **HEAT** icon appears on the display. Press the UP or DOWN buttons until the set temperature is 10 degrees above room temperature. The hot water valve will open and the fan will be running.



If cold water is available, press the MODE button repeatedly until the **COOL** icon appears on the display. Press the UP or DOWN buttons until the set temperature is 10 degrees below room temperature. The cold water valve will open and the fan will be running.



Press the UP button until the setpoint is equal to the room temperature. Press the Fan button repeatedly until a single bar appears next to the Fan icon. Confirm the fan is running on low speed. Press the Fan button again, confirm the fan is running on medium speed. Again, press the Fan button, confirm the fan is running at high speed. Press the Fan button once more, the bars next to the Fan icon should disappear.



Press the MODE button repeatedly until the **OFF** icon appears on the display. Both valves will be closed and the fan will be off.

STEP #4**TEST OPERATION****2-PIPE, NO CHANGEVER SENSOR**

Turn the power on to the Fan Coil Unit and confirm that the thermostat is programmed correctly in setup steps #3 and #4 on page 11 of the Owner's Manual.



If hot water is available, press the MODE button repeatedly until the **HEAT** icon appears on the display. Press the UP or DOWN buttons until the set temperature is 10 degrees above room temperature. The hot water valve will open and the fan will be running.



If cold water is available, press the MODE button repeatedly until the **COOL** icon appears on the display. Press the UP or DOWN buttons until the set temperature is 10 degrees below room temperature. The cold water valve will open and the fan will be running.



Press the UP button until the setpoint is equal to the room temperature. Press the Fan button repeatedly until a single bar appears next to the Fan icon. Confirm the fan is running on low speed. Press the Fan button again, confirm the fan is running on medium speed. Again, press the Fan button, confirm the fan is running at high speed. Press the Fan button once more, the bars next to the Fan icon should disappear.



Press the MODE button repeatedly until the **OFF** icon appears on the display. Both valves will be closed and the fan will be off.

STEP #4

TEST OPERATION

2-PIPE, CHANGEVER SENSOR, WITH STRIP HEAT



Turn the power on to the Fan Coil Unit and confirm that the thermostat is programmed correctly in setup steps #3 and #4 on page 11 of the Owner's Manual.



If hot water is available, press the MODE button repeatedly until the **HEAT** icon appears on the display. Press the UP or DOWN buttons until the set temperature is 10 degrees above room temperature. The hot water valve will open and the fan will be running. **The strip heat will be locked out if hot water is available.**



If hot water is not available, but your unit is equipped with a strip heat system, press the UP or DOWN buttons until the set temperature is 10 degrees below room temperature. The unit should energize the strip heaters and the fan will be running.



If cold water is available, press the MODE button repeatedly until the **COOL** icon appears on the display. Press the UP or DOWN buttons until the set temperature is 10 degrees below room temperature. The cold water valve will open and the fan will be running.

STEP #4**TEST OPERATION****2-PIPE, CHANGEOVER SENSOR, WITH STRIP HEAT**

Press the UP button until the setpoint is equal to the room temperature. Press the Fan button repeatedly until a single bar appears next to the Fan icon. Confirm the fan is running on low speed. Press the Fan button again, confirm the fan is running on medium speed. Again, press the Fan button, confirm the fan is running at high speed. Press the Fan button once more, the bars next to the Fan icon should disappear.



Press the MODE button repeatedly until the **OFF** icon appears on the display. Both valves will be closed and the fan will be off.

TROUBLESHOOTING



SYMPTOM: The fan will not run in all three speeds or switches speeds in an improper order.
CAUSE: Incorrect wiring between the thermostat and the relay board, or between the relay board and the fan wires.

REMEDY: Recheck the wiring (G=low speed, G2=medium speed, G3=high speed).



SYMPTOM: Cold water valve opens for either a cool or a heat demand in a 4-pipe system.

CAUSE: The thermostat has been programmed for the incorrect type of fan coil.

REMEDY: Confirm that you have entered the correct programming for your type of fan coil system (*steps #3 and #4, page 11 of the Owner's Manual*).



SYMPTOM: The water valve does not open at all in 2-pipe configurations.

CAUSE: The thermostat has been programmed for the incorrect type of fan coil system or the fan coil is not wired to the thermostat correctly.

REMEDY: Program the thermostat for a 2-pipe fan coil (*step #3, page 11 of the Owner's Manual*). Also, make certain that the water valve is wired to the Y1 terminal.



SYMPTOM: Parts of the thermostat display are missing.

CAUSE: The thermostat has been programmed for a minimal display.

REMEDY: Program the thermostat for Full Display (*step #1, page 10 of the Owner's Manual*).

TROUBLESHOOTING



SYMPTOM: The thermostat displays large set-point digits instead of the room temperature.

CAUSE: The thermostat has been programmed to display Single Setpoint.

REMEDY: Program the thermostat to display Dual Setpoint (*step #2, page 10 of the Owner's Manual*).



SYMPTOM: The thermostat display is stuck in Unoccupied.

CAUSE: The sensor connected to the Dry Contact terminals of the thermostat, is active, forcing the unit into 'Unoccupied.'

REMEDY: Verify proper wiring between the thermostat and the occupancy sensor and verify that the wiring is not shorted.

If no sensor is connected, program the Dry Contact polarity for Normally Open (*step #11, page 13 of the Owner's Manual*).

TROUBLESHOOTING



SYMPTOM: The thermostat will only allow Heat or Off in 2-pipe installations, even though chilled water is available.

CAUSE: Faulty, improperly wired, or improperly installed H2O changeover sensor.

REMEDY: Confirm proper wiring of the changeover sensor (between R and H2O). Confirm proper placement of the sensor (good mechanical coupling for temperature transfer).

Test the changeover sensor as follows:

1. Remove power from the fan coil system.
2. Disconnect the wire between the sensor and the H2O terminal.
3. Place an ohmmeter between R and the wire just disconnected from the sensor.
4. A good sensor will show continuity whenever the water temperature is confirmed to be at or below 65 degrees. If the sensor is open when the water temperature is confirmed to be at or below 65, replace the sensor.



1100-90006967

P/N 88-572

Rev. 2

P.O. Box 2598 • Oklahoma City, OK 73101-2598 • 405.605.5000 [phone] • 405.605.5001 [fax] • www.iec-okc.com

©2007 International Environmental Corporation (IEC). IEC is a subsidiary of LSB Industries, Inc. - AMEX symbol LXU; www.lsb-okc.com