



**There's only One Company that can
Ship your Hi-Rise Modular Fan Coil Units
in Three Weeks.**



**Yeah, You Read It Right...
Three Weeks.**

**Welcome to IEC's UMOD Program
(Universal Modular On Demand)**

IEC's innovative UMOD Quick-Ship Program means no more costly delivery or installation-related delays ... period. Your IEC Hi-Rise Modular Fan Coils arrive precisely when you expect them to — allowing you to schedule their installation far more efficiently than ever before. Welcome to the future...





NEW and only from IEC... UMOD. Universal Modular Hi-Rise Units Shipped from the Factory in just 3 Weeks!

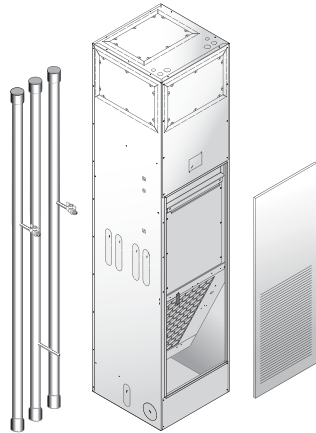

NEW! Universal Mod 300-800 CFM Units

The Concealed Universal Modular Hi-Rise (MUY) fan coil unit is now available in just 3 weeks through IEC's new Quick-Ship Program, Universal Modular On Demand (UMOD).

This product line is perfect for retrofits, renovations or new construction for low- and high-rise building applications. Knockouts allow for quick field unit conversions and installations.

- The only 3-week Modular Hi Rise fan coil unit lead time in the industry
- Select unit sizes and features available for UMOD Quick-Ship Program
- Laser cut knock-outs for easy field customization, including locations for discharge air, riser piping, condensate drain and outside air
- Easy installation and easy service
- Easy field customization
- Wide variety of coil configurations to match heating/cooling loads
- Easy-to-use computer rating program speeds up design
- Low visual impact

IEC reserves the right to continually improve its products and change design and specifications without notice.

IEC Part Number: 1100-90009207
FL-055

©2009 International Environmental Corporation, a subsidiary of LSB Industries, Inc.
NYSE symbol LXU; www.lsb-okc.com

Versatility in Design / Ease of Installation

IEC's MUY fan coil units offer versatile unit arrangements made possible as a factory-assembled and integrated package. They are designed to be of low visual impact in the room, often positioned in a corner, along the perimeter wall or as part of a partition separating two areas.

The MUY fan coil is designed for either new construction or retrofit replacement markets and can easily be field configured into any application. Riser and drain knock-outs have been strategically located on three sides of each unit for field configuration. Supply air knock-outs are located on 4 sides of the unit as well as the top of the unit (for ducted applications). Outside air knock-outs are located on each side of the return air opening. All risers ship unattached with the units so contractors can pre-install the riser system and complete riser testing prior to installation of the units.

UMOD Quick-Ship Features include:

- Nominal Sizes: 300 CFM, 400 CFM, 600 CFM, and 800 CFM
- Knock-outs for risers, drains, supply air, outside air, and electrical locations
- Cabinet dimensions: 17" x 17" x 88" (03/04); 20" x 20" x 88" (06/08)
- Risers ship in the same container as the unit
- All units include 24V thermostats that ship loose for field installation. Unit-mounted kit including tile ring and hardware comes with each unit.
- All units include arctic white return air panel
- 1" throwaway filter
- 1/2" Tuf-Skin® II unit insulation
- 2-pipe and 4-pipe coil and valve options
- Electric heat options
- Supply air grille options



International Environmental Corporation
P.O. Box 2598
Oklahoma City, OK 73101-2598

Phone: 405.605.5000 / Fax: 405.605.5001
Web: www.IEC-OKC.com